

BG95 Series QuecOpen Hardware Design

LPWA Module Series

Version: 1.3

Date: 2023-08-14

Status: Released



At Quectel, our aim is to provide timely and comprehensive services to our customers. If you require any assistance, please contact our headquarters:

Quectel Wireless Solutions Co., Ltd.

Building 5, Shanghai Business Park Phase III (Area B), No.1016 Tianlin Road, Minhang District, Shanghai 200233, China

Tel: +86 21 5108 6236

Email: info@quectel.com

Or our local offices. For more information, please visit:

<http://www.quectel.com/support/sales.htm>.

For technical support, or to report documentation errors, please visit:

<http://www.quectel.com/support/technical.htm>.

Or email us at: support@quectel.com.

Legal Notices

We offer information as a service to you. The provided information is based on your requirements and we make every effort to ensure its quality. You agree that you are responsible for using independent analysis and evaluation in designing intended products, and we provide reference designs for illustrative purposes only. Before using any hardware, software or service guided by this document, please read this notice carefully. Even though we employ commercially reasonable efforts to provide the best possible experience, you hereby acknowledge and agree that this document and related services hereunder are provided to you on an “as available” basis. We may revise or restate this document from time to time at our sole discretion without any prior notice to you.

Use and Disclosure Restrictions

License Agreements

Documents and information provided by us shall be kept confidential, unless specific permission is granted. They shall not be accessed or used for any purpose except as expressly provided herein.

Copyright

Our and third-party products hereunder may contain copyrighted material. Such copyrighted material shall not be copied, reproduced, distributed, merged, published, translated, or modified without prior written consent. We and the third party have exclusive rights over copyrighted material. No license shall be granted or conveyed under any patents, copyrights, trademarks, or service mark rights. To avoid ambiguities, purchasing in any form cannot be deemed as granting a license other than the normal non-exclusive, royalty-free license to use the material. We reserve the right to take legal action for noncompliance with abovementioned requirements, unauthorized use, or other illegal or malicious use of the material.

Trademarks

Except as otherwise set forth herein, nothing in this document shall be construed as conferring any rights to use any trademark, trade name or name, abbreviation, or counterfeit product thereof owned by Quectel or any third party in advertising, publicity, or other aspects.

Third-Party Rights

This document may refer to hardware, software and/or documentation owned by one or more third parties (“third-party materials”). Use of such third-party materials shall be governed by all restrictions and obligations applicable thereto.

We make no warranty or representation, either express or implied, regarding the third-party materials, including but not limited to any implied or statutory, warranties of merchantability or fitness for a particular purpose, quiet enjoyment, system integration, information accuracy, and non-infringement of any third-party intellectual property rights with regard to the licensed technology or use thereof. Nothing herein constitutes a representation or warranty by us to either develop, enhance, modify, distribute, market, sell, offer for sale, or otherwise maintain production of any our products or any other hardware, software, device, tool, information, or product. We moreover disclaim any and all warranties arising from the course of dealing or usage of trade.

Privacy Policy

To implement module functionality, certain device data are uploaded to Quectel’s or third-party’s servers, including carriers, chipset suppliers or customer-designated servers. Quectel, strictly abiding by the relevant laws and regulations, shall retain, use, disclose or otherwise process relevant data for the purpose of performing the service only or as permitted by applicable laws. Before data interaction with third parties, please be informed of their privacy and data security policy.

Disclaimer

- a) We acknowledge no liability for any injury or damage arising from the reliance upon the information.
- b) We shall bear no liability resulting from any inaccuracies or omissions, or from the use of the information contained herein.
- c) While we have made every effort to ensure that the functions and features under development are free from errors, it is possible that they could contain errors, inaccuracies, and omissions. Unless otherwise provided by valid agreement, we make no warranties of any kind, either implied or express, and exclude all liability for any loss or damage suffered in connection with the use of features and functions under development, to the maximum extent permitted by law, regardless of whether such loss or damage may have been foreseeable.
- d) We are not responsible for the accessibility, safety, accuracy, availability, legality, or completeness of information, advertising, commercial offers, products, services, and materials on third-party websites and third-party resources.

Copyright © Quectel Wireless Solutions Co., Ltd. 2023. All rights reserved

Safety Information

The following safety precautions must be observed during all phases of operation, such as usage, service or repair of any terminal or mobile incorporating the module. Manufacturers of the cellular terminal should notify users and operating personnel of the following safety information by incorporating these guidelines into all manuals of the product. Otherwise, Quectel assumes no liability for customers' failure to comply with these precautions.



Full attention must be paid to driving at all times in order to reduce the risk of an accident. Using a mobile while driving (even with a handsfree kit) causes distraction and can lead to an accident. Please comply with laws and regulations restricting the use of wireless devices while driving.



Switch off the cellular terminal or mobile before boarding an aircraft. The operation of wireless appliances in an aircraft is forbidden to prevent interference with communication systems. If there is an Airplane Mode, it should be enabled prior to boarding an aircraft. Please consult the airline staff for more restrictions on the use of wireless devices on an aircraft.



Wireless devices may cause interference on sensitive medical equipment, so please be aware of the restrictions on the use of wireless devices when in hospitals, clinics or other healthcare facilities.



Cellular terminals or mobiles operating over radio signal and cellular network cannot be guaranteed to connect in certain conditions, such as when the mobile bill is unpaid or the (U)SIM card is invalid. When emergency help is needed in such conditions, use emergency call if the device supports it. In order to make or receive a call, the cellular terminal or mobile must be switched on in a service area with adequate cellular signal strength. In an emergency, the device with emergency call function cannot be used as the only contact method considering network connection cannot be guaranteed under all circumstances.



The cellular terminal or mobile contains a transceiver. When it is ON, it receives and transmits radio frequency signals. RF interference can occur if it is used close to TV sets, radios, computers or other electric equipment.



In locations with explosive or potentially explosive atmospheres, obey all posted signs and turn off wireless devices such as mobile phone or other cellular terminals. Areas with explosive or potentially explosive atmospheres include fuelling areas, below decks on boats, fuel or chemical transfer or storage facilities, and areas where the air contains chemicals or particles such as grain, dust or metal powders.

About the Document

Revision History

Version	Date	Author	Description
1.0	2019-12-20	Lyndon LIU/ Hyman DING/ Watt ZHU	Initial
1.1	2021-03-02	Lex LI/ Reuben BAO/ Justice HAN	<ol style="list-style-type: none"> 1. Deleted BG95-N1. 2. Added BG95-M6. 3. Completed the information of BG95-MF. 4. Added the supply voltage range of BG95-M4. 5. Removed B14 for LTE Cat M1 and B26 for LTE Cat NB2. 6. Updated the GNSS function into a standard configuration. 7. Updated the dimensional tolerance of the module (Table 4 and Chapter 7). 8. Updated the functional diagram (Chapter 2.3). 9. Added a reference design for auto power-on (Chapter 3.7.1). 10. Updated the reference design of PON_TRIG (Figure 19). 11. Updated the GNSS performance (Table 33). 12. Updated the current consumption values of BG95-M3, and added current consumption tables for other module models (Chapter 6.4). 13. Added the RF output power of BG95-M4/-M5/-M6 (Chapter 6.5). 14. Updated the conducted RF receiving sensitivity of BG95-M1/-M2/-M3 and added that of BG95-M4/-M5/ -M6/-MF (Chapter 6.6). 15. Updated electrostatic discharge characteristics (Table 68). 16. Updated the description of storage conditions (Chapter

			8.1).
			17. Updated the recommended reflow soldering thermal profile parameters (Chapter 8.2).
			18. Added the JATE and TELEC certification ID of BG95-M1/-M2/-M3/-M6 (Appendix E).
1.2	2022-10-12	Bayes YANG/ Ben JIANG/ Matt YE	<ol style="list-style-type: none"> 1. Added the footnote about the power class of BG95-M4 in Table 3. 2. Added the high-speed mode and updated the USB serial drivers supported by the USB interface in Table 4. 3. Updated the baud rates supported by the main UART in Chapter 3.13. 4. Updated the function of SPI interfaces in Table 4 and Chapter 3.15. 5. Updated the minimum width of VBAT_RF trace from 2 mm to 2.7 mm, and updated the reference design of power supply in Chapter 3.7.2. 6. Updated the reference design of PON_TRIG in Figure 19. 7. Updated the typical value of ADC resolution in Table 25. 8. Updated the GNSS performance accuracy in Table 33. 9. Updated the information of Wi-Fi antenna interface in Chapter 5.3 and Table 40 and Table 58. 10. Updated the VSWR of GNSS in Table 40. 11. Updated the supported baud rates of main UART in Chapter 3.13. 12. Updated the UART3 reference design in Figure 25. 13. Updated the I_{VBAT} and USB_VBUS power supply ratings information in Table 42. 14. Added BG95-M4 Tx power information of power class 2 in Table 60. 15. Updated some recommended soldering thermal profile parameters and added the information about ultrasonic technology in cleaning the module in Chapter 8.2.
1.3	2023-08-14	Bayes YANG Pearl GUO/ Matt YE	<ol style="list-style-type: none"> 1. Added the following applicable modules: BG95-M8 and BG95-M9. 2. Updated the USB serial drivers in Table 4. 3. Added BG95-M9 GNSS power consumption data of open sky under real network in Table 61. 4. Added a note of the maximum output power of GNSS transmission in Chapter 6.5. 5. Updated BG95-M4 conducted Rx sensitivity in Table 71. 6. Updated the mechanical information in Figure 44, Figure 45 and Figure 46.

-
7. Added the information of mounting direction in Chapter 8.3.3.
-

Contents

Safety Information	3
About the Document	4
Contents	7
Table Index	10
Figure Index	12
1 Introduction	14
1.1. Special Mark.....	14
2 Product Overview	15
2.1. General Description.....	15
2.2. Key Features.....	18
2.3. Functional Diagram.....	20
2.4. EVB Kit.....	25
3 Application Interfaces	26
3.1. General Description.....	26
3.2. Pin Assignment.....	27
3.3. Pin Description.....	28
3.4. Pin Multiplexing Assignment.....	34
3.5. Operating Modes.....	36
3.6. Power Saving.....	37
3.6.1. Airplane Mode.....	37
3.6.2. Power Saving Mode (PSM).....	37
3.6.3. Extended Idle Mode DRX (e-I-DRX).....	38
3.6.4. Sleep Mode.....	38
3.6.4.1. UART Application.....	38
3.7. Power Supply.....	39
3.7.1. Power Supply Pins.....	39
3.7.2. Voltage Stability Requirements.....	40
3.7.3. Power Supply Voltage Monitoring.....	41
3.8. Turn On and Off.....	42
3.8.1. Turn On with PWRKEY.....	42
3.8.2. Turn Off.....	44
3.8.2.1. Turn Off with PWRKEY.....	45
3.8.2.2. Turn Off with API.....	45
3.9. Reset.....	45
3.10. PON_TRIG Interface.....	47
3.11. (U)SIM Interface.....	48
3.12. USB Interface.....	50
3.13. UART.....	52
3.14. I2C Interface.....	56
3.15. SPI Interfaces.....	57

3.16.	ADC Interfaces	59
3.17.	MAIN_RI	60
3.18.	Network Status Indication	60
3.19.	STATUS	61
3.20.	USB_BOOT	62
3.21.	GRFC Interfaces	64
4	GNSS	65
4.1.	General Description	65
4.2.	GNSS Performance	65
4.3.	Layout Guidelines	66
5	Antenna Interfaces.....	67
5.1.	Main Antenna Interface	67
5.1.1.	Pin Definition	67
5.1.2.	Operating Frequency	67
5.1.3.	Reference Design	69
5.2.	GNSS Antenna Interface.....	69
5.2.1.	Pin Definition	69
5.2.2.	GNSS Operating Frequency	70
5.2.3.	Reference Design	70
5.3.	Wi-Fi Antenna Interface	71
5.3.1.	Pin Definition	71
5.3.2.	Wi-Fi Operating Frequency.....	71
5.3.3.	Reference Design	71
5.4.	RF Routing Guidelines.....	72
5.5.	Antenna Installation	74
5.5.1.	Antenna Design Requirements	74
5.5.2.	RF Connector Recommendation	75
6	Electrical Characteristics and Reliability	77
6.1.	Absolute Maximum Ratings	77
6.2.	Power Supply Ratings.....	77
6.3.	Operating and Storage Temperatures	78
6.4.	Power Consumption.....	79
6.5.	Tx Power	103
6.6.	Rx Sensitivity.....	105
6.7.	ESD Protection.....	115
7	Mechanical Dimensions	116
7.1.	Mechanical Dimensions	116
7.2.	Recommended Footprint	118
7.3.	Top and Bottom Views	119
8	Storage, Manufacturing and Packaging	120
8.1.	Storage Conditions.....	120
8.2.	Manufacturing and Soldering.....	121

8.3.	Packaging Specifications	122
8.3.1.	Carrier Tape.....	123
8.3.2.	Plastic Reel	123
8.3.3.	Mounting Direction	124
8.3.4.	Packaging Process	124
9	Appendix A References.....	126
10	Appendix B Compulsory Certifications.....	130

Table Index

Table 1: Special Mark.....	14
Table 2: Different Selections of the Module	15
Table 3: Frequency Bands and GNSS Types	16
Table 4: Key Features	18
Table 5: Definition of I/O Parameters	28
Table 6: Pin Description	29
Table 7: Multiplexing Pins.....	34
Table 8: Pull-up/Pull-down Resistance of GPIOs.....	35
Table 9: Overview of Operating Modes.....	36
Table 10: VBAT and GND Pins	39
Table 11: PWRKEY Pin Definition	42
Table 12: Pin Definition of RESET_N.....	46
Table 13: Pin Definition of PON_TRIG Interface.....	47
Table 14: Pin Definition of (U)SIM Interface.....	48
Table 15: Pin Definition of USB Interface.....	50
Table 16: Pin Definition of Main UART.....	52
Table 17: Pin Definition of UART1.....	53
Table 18: Pin Definition of UART2.....	53
Table 19: Pin Definition of UART3.....	53
Table 20: Pin Definition of the I2C Interface	56
Table 21: Pin Definition of the SPI1 Interface	57
Table 22: Pin Definition of the SPI2 Interface	57
Table 23: Parameters of SPI Timing at 50 MHz.....	58
Table 24: Pin Definition of ADC Interfaces.....	59
Table 25: Characteristics of ADC Interfaces	59
Table 26: Default Behaviours of MAIN_RI	60
Table 27: Pin Definition of NET_STATUS	60
Table 28: Operating Status of NET_STATUS	61
Table 29: Pin Definition of STATUS.....	61
Table 30: Pin Definition of USB_BOOT Interface	62
Table 31: Pin Definition of GRFC Interfaces	64
Table 32: Truth Table of GRFC Interfaces.....	64
Table 33: GNSS Performance.....	65
Table 34: Pin Definition of the Main Antenna Interface.....	67
Table 35: Operating Frequency.....	67
Table 36: Pin Definition of GNSS Antenna Interface	69
Table 37: GNSS Operating Frequency	70
Table 38: Pin Definition of Wi-Fi Antenna Interface	71
Table 39: Wi-Fi Operating Frequency	71
Table 40: Antenna Requirements.....	74
Table 41: Absolute Maximum Ratings.....	77

Table 42: Power Supply Ratings	77
Table 43: Operating and Storage Temperatures.....	78
Table 44: BG95-M1 Power Consumption (3.3 V Power Supply, Room Temperature)	79
Table 45: BG95-M2 Power Consumption (3.3 V Power Supply, Room Temperature)	80
Table 46: BG95-M3 Power Consumption (3.8 V Power Supply, Room Temperature)	82
Table 47: BG95-M4 Power Consumption (3.8 V Power Supply, Room Temperature)	85
Table 48: BG95-M5 Power Consumption (3.8 V Power Supply, Room Temperature)	87
Table 49: BG95-M6 Power Consumption (3.8 V Power Supply, Room Temperature)	90
Table 50: BG95-MF Power Consumption (3.8 V Power Supply, Room Temperature).....	92
Table 51: BG95-M8 Power Consumption (3.8 V Power Supply, Room Temperature)	94
Table 52: BG95-M9 Power Consumption (3.8 V Power Supply, Room Temperature)	96
Table 53: GNSS Power Consumption of BG95-M1 (3.3 V Power Supply, Room Temperature).....	99
Table 54: GNSS Power Consumption of BG95-M2 (3.3 V Power Supply, Room Temperature).....	99
Table 55: GNSS Power Consumption of BG95-M3 (3.8 V Power Supply, Room Temperature).....	100
Table 56: GNSS Power Consumption of BG95-M4 (3.8 V Power Supply, Room Temperature).....	100
Table 57: GNSS Power Consumption of BG95-M5 (3.8 V Power Supply, Room Temperature).....	101
Table 58: GNSS Power Consumption of BG95-M6 (3.8 V Power Supply, Room Temperature).....	101
Table 59: GNSS Power Consumption of BG95-MF (3.8 V Power Supply, Room Temperature).....	102
Table 60: GNSS Power Consumption of BG95-M8 (3.8 V Power Supply, Room Temperature).....	102
Table 61: GNSS Power Consumption of BG95-M9 (3.8 V Power Supply, Room Temperature).....	103
Table 62: Wi-Fi Power Consumption of BG95-MF (3.8 V Power Supply, Room Temperature)	103
Table 63: Conducted Tx Power of BG95-M1/-M2/-M3/-MF	103
Table 64: Conducted Tx Power of BG95-M4	104
Table 65: Conducted Tx Power of BG95-M5/-M6	104
Table 66: Conducted Tx Power of BG95-M8	104
Table 67: Conducted Tx Power of BG95-M9	105
Table 68: Conducted Rx Sensitivity of BG95-M1	105
Table 69: Conducted Rx Sensitivity of BG95-M2.....	106
Table 70: Conducted Rx Sensitivity of BG95-M3.....	107
Table 71: Conducted Rx Sensitivity of BG95-M4.....	108
Table 72: Conducted Rx Sensitivity of BG95-M5.....	109
Table 73: Conducted Rx Sensitivity of BG95-M6.....	110
Table 74: Conducted Rx Sensitivity of BG95-MF.....	111
Table 75: Wi-Fi Conducted Rx Sensitivity of BG95-MF	112
Table 76: Conducted Rx Sensitivity of BG95-M8.....	112
Table 77: Conducted Rx Sensitivity of BG95-M9.....	113
Table 78: Electrostatic Discharge Characteristics (Temperature: 25–30 °C, Humidity: 40 ±5 %).....	115
Table 79: Recommended Thermal Profile Parameters.....	122
Table 80: Carrier Tape Dimension Table (Unit: mm)	123
Table 81: Plastic Reel Dimension Table (Unit: mm).....	124
Table 82: Packaging Specifications of the Module	125
Table 83: Related Documents	126
Table 84: Terms and Abbreviations	126

Figure Index

Figure 1: Functional Diagram of BG95-M1/-M2..... 21

Figure 2: Functional Diagram of BG95-M3 21

Figure 3: Functional Diagram of BG95-M4 22

Figure 4: Functional Diagram of BG95-M5 22

Figure 5: Functional Diagram of BG95-M6 23

Figure 6: Functional Diagram of BG95-MF 23

Figure 7: Functional Diagram of BG95-M8 24

Figure 8: Functional Diagram of BG95-M9 24

Figure 9: Pin Assignment (Top View) 27

Figure 10: Sleep Mode Application via UART 39

Figure 11: Power Supply Limits During Burst Transmission (BG95-M3/-M5/-M8) 40

Figure 12: Star Structure of the Power Supply 41

Figure 13: Auto Turn-On Circuit 42

Figure 14: Turn On with a Driver Circuit..... 43

Figure 15: Turn on the Module with a Push Button..... 43

Figure 16: Power-up Timing 44

Figure 17: Power-down Timing 45

Figure 18: A Reference Design of RESET_N with a Driver Circuit..... 46

Figure 19: A Reference Design of RESET_N with a Push Button..... 46

Figure 20: Reset Timing 47

Figure 21: A Reference Design of PON_TRIG 48

Figure 22: A Reference Design of (U)SIM Interface with an 8-Pin (U)SIM Card Connector 49

Figure 23: A Reference Design of (U)SIM Interface with a 6-Pin (U)SIM Card Connector 49

Figure 24: Reference Design of USB Interface 51

Figure 25: A Reference Design of the Main UART (IC Solution)..... 54

Figure 26: A Reference Design of the Main UART (Transistor Solution)..... 55

Figure 27: A Reference Design of UART3 (IC Solution Without Internal Pull-up)..... 55

Figure 28: A Reference Design of I2C Interface with an External I2C Interface Sensor..... 56

Figure 29: SPI Timing (Master Mode) 58

Figure 30: A Reference Design of NET_STATUS 61

Figure 31: A Reference Design of STATUS 62

Figure 32: A Reference Design of USB_BOOT Interface 63

Figure 33: Timing for Turning on the Module with USB_BOOT..... 63

Figure 34: A Reference Design of the Main Antenna Interface 69

Figure 35: A Reference Design of GNSS Antenna Interface 70

Figure 36: A Reference Design of Wi-Fi Antenna Interface 71

Figure 37: Microstrip Design on a 2-layer PCB 72

Figure 38: Coplanar Waveguide Design on a 2-layer PCB 72

Figure 39: Coplanar Waveguide Design on a 4-layer PCB (Layer 3 as Reference Ground)..... 73

Figure 40: Coplanar Waveguide Design on a 4-layer PCB (Layer 4 as Reference Ground)..... 73

Figure 41: Dimensions of the Receptacle (Unit: mm)..... 75

Figure 42: Specifications of Mated Plugs	75
Figure 43: Space Factor of Mated Connectors (Unit: mm).....	76
Figure 44: Module Top and Side Dimensions	116
Figure 45: Bottom Dimensions (Bottom View).....	117
Figure 46: Recommended Footprint (Top View).....	118
Figure 47: Top and Bottom Views	119
Figure 48: Recommended Reflow Soldering Thermal Profile	121
Figure 49: Carrier Tape Dimension Drawing.....	123
Figure 50: Plastic Reel Dimension Drawing	123
Figure 51: Mounting Direction	124
Figure 52: Packaging Process	125
Figure 53: JATE/TELEC Certification ID of BG95-M1/-M2	130
Figure 54: JATE/TELEC Certification ID of BG95-M3	130
Figure 55: JATE/TELEC Certification ID of BG95-M5	130
Figure 56: JATE/TELEC Certification ID of BG95-M6	131

1 Introduction

QuecOpen[®] is a solution where the module acts as the main processor. Constant transition and evolution of both the communication technology and the market highlight its merits. It can help you to:

- Realize embedded applications' quick development and shorten product R&D cycle
- Simplify circuit and hardware structure design to reduce engineering costs
- Miniaturize products
- Reduce product power consumption
- Apply OTA technology
- Enhance product competitiveness and price-performance ratio

This document, describing BG95 series QuecOpen[®] module and its air interface and hardware interfaces connected to your applications, provides you with the interface specifications, electrical and mechanical details, as well as other related information of the module.

The module is a baseband processor platform based on ARM Cortex A7. The maximum dominant frequency is up to 800 MHz. You can use the module as the basis for development of QuecOpen[®] applications.

With the application notes and user guides provided separately, you can easily use the module to design and set up mobile applications.

1.1. Special Mark

Table 1: Special Mark

Mark	Definition
*	Unless otherwise specified, when an asterisk (*) is used after a function, feature, interface, pin name, AT command, or argument, it indicates that the function, feature, interface, pin, AT command, or argument is under development and currently not supported; and the asterisk (*) after a model indicates that the sample of the model is currently unavailable.

2 Product Overview

2.1. General Description

As an embedded IoT (LTE Cat M1, LTE Cat NB2 ¹ and EGPRS) wireless communication module, it provides data connectivity on LTE HD-FDD and GPRS/EGPRS networks. It also provides GNSS function to meet your specific application demands.

The module is based on an architecture in which WWAN and GNSS Rx chains share certain hardware blocks. However, the module does not support concurrent operation of WWAN and GNSS. The solution adopted in the module is a form of coarse time-division multiplexing (TDM) between WWAN and GNSS Rx chains. Given the relaxed latency requirements of most LPWA applications, time-division sharing of resources can be made largely transparent to applications. For more details, see **document [1]**.

The module is an industrial-grade module for industrial and commercial applications only.

Table 2: Different Selections of the Module

Model	Cat M1	Cat NB2 ¹	GSM	Wi-Fi Scan	GNSS
BG95-M1	√	-	-	-	√
BG95-M2	√	√	-	-	√
BG95-M3	√	√	√	-	√
BG95-M4	√	√	-	-	√
BG95-M5	√	√	√	-	√
BG95-M6	√	√	-	-	√
BG95-MF	√	√	-	√	√
BG95-M8	√	√	√	-	√

¹ LTE Cat NB2 is backward compatible with LTE Cat NB1.

BG95-M9	√	√	-	-	√
---------	---	---	---	---	---

NOTE

1. √: Supported.
2. -: Not supported.

Table 3: Frequency Bands and GNSS Types

Model	Supported Bands	LTE Bands Power Class	GNSS
BG95-M1	Cat M1 Only: LTE HD-FDD: B1/B2/B3/B4/B5/B8/B12/B13/B18/B19/ B20/B25/B26/B27/B28/B66/B85	Power Class 5 (21 dBm)	GPS, GLONASS, BDS, Galileo, QZSS
BG95-M2	Cat M1: LTE HD-FDD: B1/B2/B3/B4/B5/B8/B12/B13/B18/B19/ B20/B25/B26/B27/B28/B66/B85 Cat NB2: LTE HD-FDD: B1/B2/B3/B4/B5/B8/B12/B13/B18/B19/ B20/B25/B28/B66/B71/B85	Power Class 5 (21 dBm)	GPS, GLONASS, BDS, Galileo, QZSS
BG95-M3	Cat M1: LTE HD-FDD: B1/B2/B3/B4/B5/B8/B12/B13/B18/B19/ B20/B25/B26/B27/B28/B66/B85 Cat NB2: LTE HD-FDD: B1/B2/B3/B4/B5/B8/B12/B13/B18/B19/ B20/B25/B28/B66/B71/B85 EGPRS: GSM850/EGSM900/DCS1800/ PCS1900	Power Class 5 (21 dBm)	GPS, GLONASS, BDS, Galileo, QZSS
BG95-M4	Cat M1: LTE HD-FDD: B1/B2/B3/B4/B5/B8/B12/B13/B18/B19/ B20/B25/B26/B27/B28/B31/B66/B72/ B73/B85 Cat NB2:	Power Class 2 (26 dBm) ² @ B31/B72/B73 Power Class 3 (23 dBm) ² @ B31/B72/B73	GPS, GLONASS, BDS, Galileo, QZSS

² LTE HD-FDD B31, B72 and B73 on BG95-M4 support either Power Class 2 (26 dBm) or Power Class 3 (23 dBm). For more details, consult Quectel Technical Support (support@quectel.com).

	<p>LTE HD-FDD: B1/B2/B3/B4/B5/B8/B12/B13/B18/B19/ B20/B25/B28/B31/B66/B72/B73/B85</p>	<p>Power Class 5 (21 dBm) @ other LTE bands</p>	
BG95-M5	<p>Cat M1: LTE HD-FDD: B1/B2/B3/B4/B5/B8/B12/B13/B18/B19/ B20/B25/B26/B27/B28/B66/B85</p> <p>Cat NB2: LTE HD-FDD: B1/B2/B3/B4/B5/B8/B12/B13/B18/B19/ B20/B25/B28/B66/B71/B85</p> <p>EGPRS: GSM850/EGSM900/DCS1800/ PCS1900</p>	<p>Power Class 3 (23 dBm)</p>	<p>GPS, GLONASS, BDS, Galileo, QZSS</p>
BG95-M6	<p>Cat M1: LTE HD-FDD: B1/B2/B3/B4/B5/B8/B12/B13/B18/B19/ B20/B25/B26/B27/B28/B66/B85</p> <p>Cat NB2: LTE HD-FDD: B1/B2/B3/B4/B5/B8/B12/B13/B18/B19/ B20/B25/B28/B66/B71/B85</p>	<p>Power Class 3 (23 dBm)</p>	<p>GPS, GLONASS, BDS, Galileo, QZSS</p>
BG95-MF	<p>Cat M1: LTE HD-FDD: B1/B2/B3/B4/B5/B8/B12/B13/B18/B19/ B20/B25/B26/B27/B28/B66/B85</p> <p>Cat NB2: LTE HD-FDD: B1/B2/B3/B4/B5/B8/B12/B13/B18/B19/ B20/B25/B28/B66/B71/B85</p> <p>Wi-Fi Scan: 2.4 GHz</p>	<p>Power Class 5 (21 dBm)</p>	<p>GPS, GLONASS, BDS, Galileo, QZSS</p>
BG95-M8	<p>Cat M1: LTE HD-FDD: B1/B2/B3/B4/B5/B8/B12/B13/B18/B19/ B20/B25/B26/B27/B28/B31/B66/B72/ B73/B85</p> <p>Cat NB2: LTE HD-FDD: B1/B2/B3/B4/B5/B8/B12/B13/B18/B19/ B20/B25/B28/B31/B66/B72/B73/B85</p> <p>EGPRS: GSM850/EGSM900/DCS1800/ PCS1900</p>	<p>Power Class 2 (26 dBm) @ B31/B72/B73</p> <p>Power Class 5 (21 dBm) @ other LTE bands</p>	<p>GPS, GLONASS, BDS, Galileo, QZSS</p>

BG95-M9	Cat M1: LTE HD-FDD: B1/B2/B3/B4/B5/B8/B12/B13/B18/B19/ B20/B25/B26/B27/B28/B31/B66/B72/ B73/B85/B87/B88	Power Class 2 (26 dBm) @ B31/B72/B73	GPS, GLONASS, BDS, Galileo, QZSS
	Cat NB2: LTE HD-FDD: B1/B2/B3/B4/B5/B8/B12/B13/B18/B19/ B20/B25/B28/B31/B66/B72/B73/B85/ B86/B87/B88	Power Class 3 (23 dBm) @ other LTE bands	

As a type of SMD, the module can be embedded into applications through its 102 LGA pins. With a compact profile of 23.6 mm × 19.9 mm × 2.2 mm, it can meet most requirements for M2M applications such as security, smart metering, tracking system, and wireless POS.

2.2. Key Features

Table 4: Key Features

Features	Details
Power Supply	BG95-M1/-M2: <ul style="list-style-type: none"> ● Supply voltage³: 2.6–4.8 V ● Typical supply voltage: 3.3 V
	BG95-M3/-M5/-M6/-MF/-M8: <ul style="list-style-type: none"> ● Supply voltage: 3.3–4.3 V ● Typical supply voltage: 3.8 V
	BG95-M4/-M9: <ul style="list-style-type: none"> ● Supply voltage: 3.2–4.2 V ● Typical supply voltage: 3.8 V
Transmitting Power ⁴	LTE HD-FDD bands: <ul style="list-style-type: none"> ● Class 5 (21 dBm +1.7/-3 dB) ● Class 3 (23 dBm ±2 dB) ● Class 2 (26 dBm ±2 dB)
	GSM bands: <ul style="list-style-type: none"> ● Class 4 (33 dBm ±2 dB) for GSM850 ● Class 4 (33 dBm ±2 dB) for EGSM900 ● Class 1 (30 dBm ±2 dB) for DCS1800

³ For every VBAT transition/re-insertion from 0 V, the minimum power supply voltage should be higher than 2.7 V. After the module starts up normally, the minimum safety voltage is 2.6 V. To ensure full-function mode, the minimum power supply voltage should be higher than 2.8 V.

⁴ See **Table 3** or **Chapter 6.5** for the LTE bands power class level of each model.

	<ul style="list-style-type: none"> ● Class 1 (30 dBm ±2 dB) for PCS1900 ● Class E2 (27 dBm ±3 dB) for GSM850 8-PSK ● Class E2 (27 dBm ±3 dB) for EGSM900 8-PSK ● Class E2 (26 dBm ±3 dB) for DCS1800 8-PSK ● Class E2 (26 dBm ±3 dB) for PCS1900 8-PSK
LTE Features ⁵	<ul style="list-style-type: none"> ● Supports 3GPP Rel-14 ● Supports LTE Cat M1 and LTE Cat NB2 ● Supports 1.4 MHz RF bandwidth for LTE Cat M1 ● Supports 200 kHz RF bandwidth for LTE Cat NB2 ● Max. transmission data rates: Cat M1: 588 kbps (DL)/1119 kbps (UL) Cat NB2: 127 kbps (DL)/158.5 kbps (UL)
GSM Features ⁵	<p>GPRS:</p> <ul style="list-style-type: none"> ● Supports GPRS multi-slot class 33 (33 by default) ● Coding scheme: CS 1–4 ● Max. 107 kbps (DL)/85.6 kbps (UL) <p>EDGE:</p> <ul style="list-style-type: none"> ● Supports EDGE multi-slot class 33 (33 by default) ● Supports GMSK and 8-PSK for different MCS (Modulation and Coding Scheme) ● Downlink coding schemes: MCS 1–9 ● Uplink coding schemes: MCS 1–9 ● Max. 296 kbps (DL)/236.8 kbps (UL)
Internet Protocol Features	<ul style="list-style-type: none"> ● Supports PPP/TCP/UDP/SSL/TLS/FTP(S)/HTTP(S)/NITZ/PING/MQTT /LwM2M/CoAP/IPv6 protocols ● Supports PAP and CHAP for PPP connections
SMS	<ul style="list-style-type: none"> ● Text and PDU mode ● Point-to-point MO and MT ● SMS cell broadcast ● SMS storage: ME by default
(U)SIM Interface	Supports 1.8 V USIM/SIM card only
USB Interface	<ul style="list-style-type: none"> ● Compliant with USB 2.0 specification (slave only) ● Supports operations at high-speed, full-speed and low-speed modes ● Used for AT command communication, data transmission ⁶, GNSS NMEA sentences output, software debugging and firmware upgrade ● Supports USB serial drivers for Windows 7/8/8.1/10/11, Linux 2.6–6.5, Android 4.x–13.x
UART	<p>Main UART:</p> <ul style="list-style-type: none"> ● Used for AT command communication and data communication ● 115200 bps by default ● The default frame format is 8N1 (8 data bits, no parity, 1 stop bit)

⁵ See **Table 3** or **Chapter 6.5** for the LTE and GSM features of each model.

⁶ It is not recommended to use USB for data communication, as the use of USB will increase the power consumption.

	<ul style="list-style-type: none"> ● Supports RTS and CTS hardware flow control <p>UART1/UART2/UART3:</p> <ul style="list-style-type: none"> ● Used for communication with peripherals ● Multiplexed from GPIOs (see Table 7 for details)
SPI Interfaces	<p>SPI1/SPI2:</p> <ul style="list-style-type: none"> ● Support master mode only ● Up to 50 MHz in master mode
I2C Interface	<ul style="list-style-type: none"> ● Master mode only ● Supports fast-mode plus
GNSS Features	<ul style="list-style-type: none"> ● GPS, GLONASS, BDS, Galileo and QZSS ● 1 Hz data update rate by default
AT Commands	<ul style="list-style-type: none"> ● 3GPP TS 27.007 and 3GPP TS 27.005 AT commands ● Quectel enhanced AT commands
Network Indication	One NET_STATUS pin for network connectivity status indication
Antenna Interfaces	<ul style="list-style-type: none"> ● Main antenna interface (ANT_MAIN) ● GNSS antenna interface (ANT_GNSS) ● Wi-Fi antenna interface (ANT_WIFI, for BG95-MF only)
Physical Characteristics	<ul style="list-style-type: none"> ● Dimensions: (23.6 ±0.2) mm × (19.9 ±0.2) mm × (2.2 ±0.2) mm ● Weight: approx. 2.15 g
Temperature Range	<ul style="list-style-type: none"> ● Operating temperature range: -35 °C to +75 °C ⁷ ● Extended temperature range: -40 °C to +85 °C ⁸ ● Storage temperature range: -40 °C to +90 °C
Firmware Upgrade	USB interface, DFOTA
RoHS	All hardware components are fully compliant with EU RoHS directive

2.3. Functional Diagram

The following figures show the block diagram of the modules and illustrate the major functional parts.

- Power management
- Baseband
- Radio frequency
- Peripheral interfaces

⁷ Within the operating temperature range, the module meets 3GPP specifications.

⁸ Within the extended temperature range, the module remains the ability to establish and maintain functions such as SMS and data transmission, without any unrecoverable malfunction. Radio spectrum and radio network are not influenced, while one or more specifications, such as P_{out}, may exceed the specified tolerances of 3GPP. When the temperature returns to the operating temperature range, the module meets 3GPP specifications again.

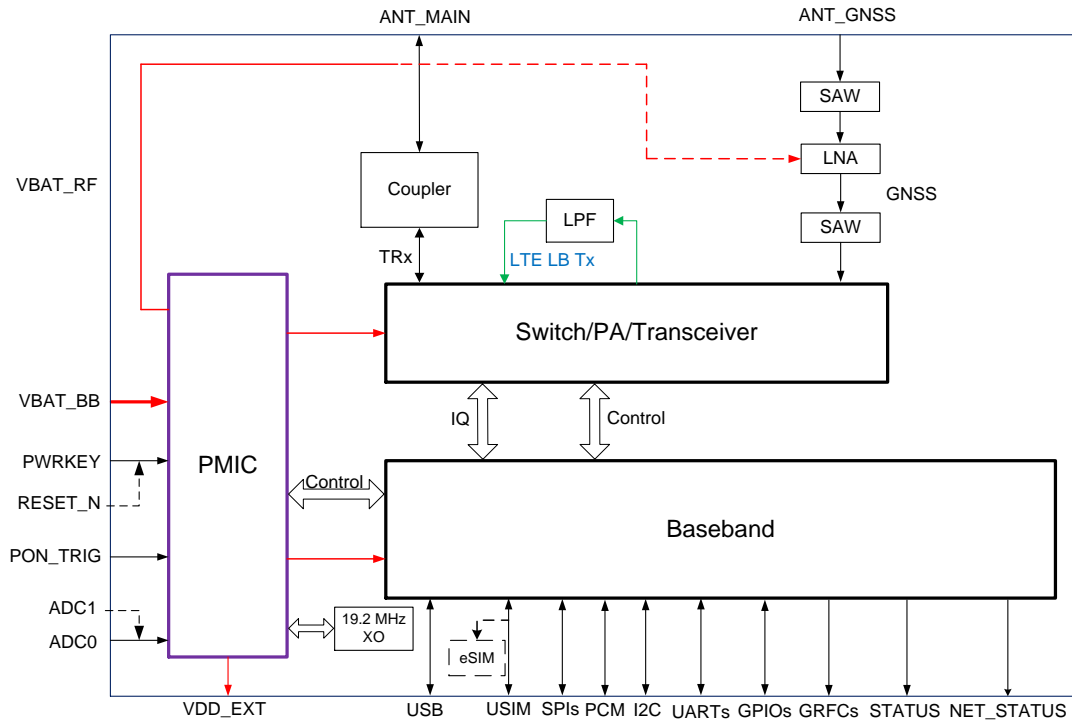

Figure 1: Functional Diagram of BG95-M1/M2

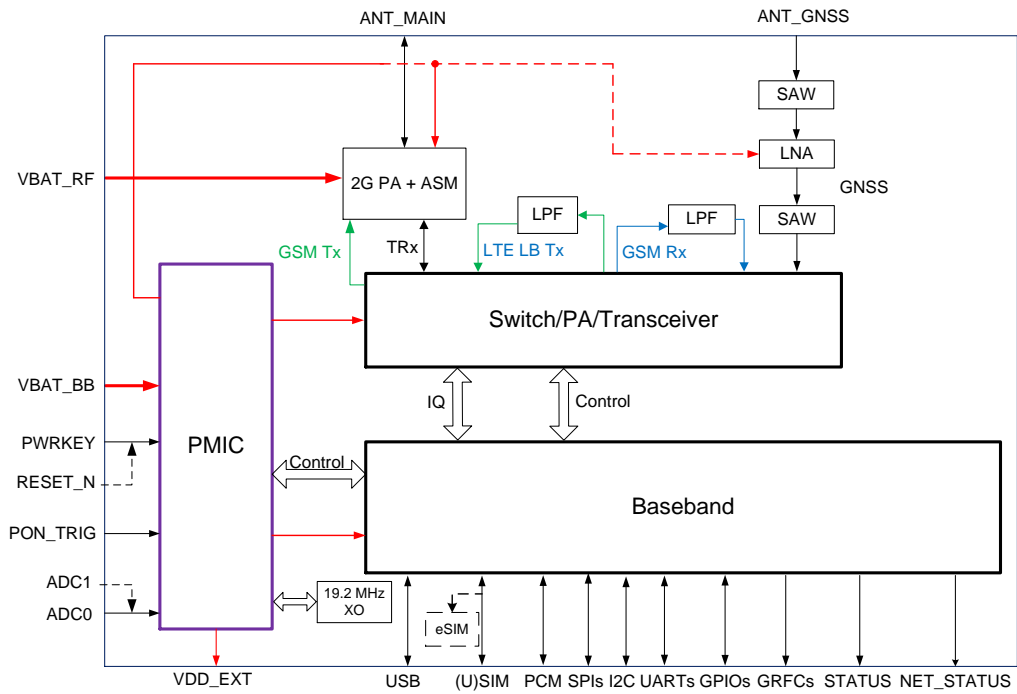

Figure 2: Functional Diagram of BG95-M3

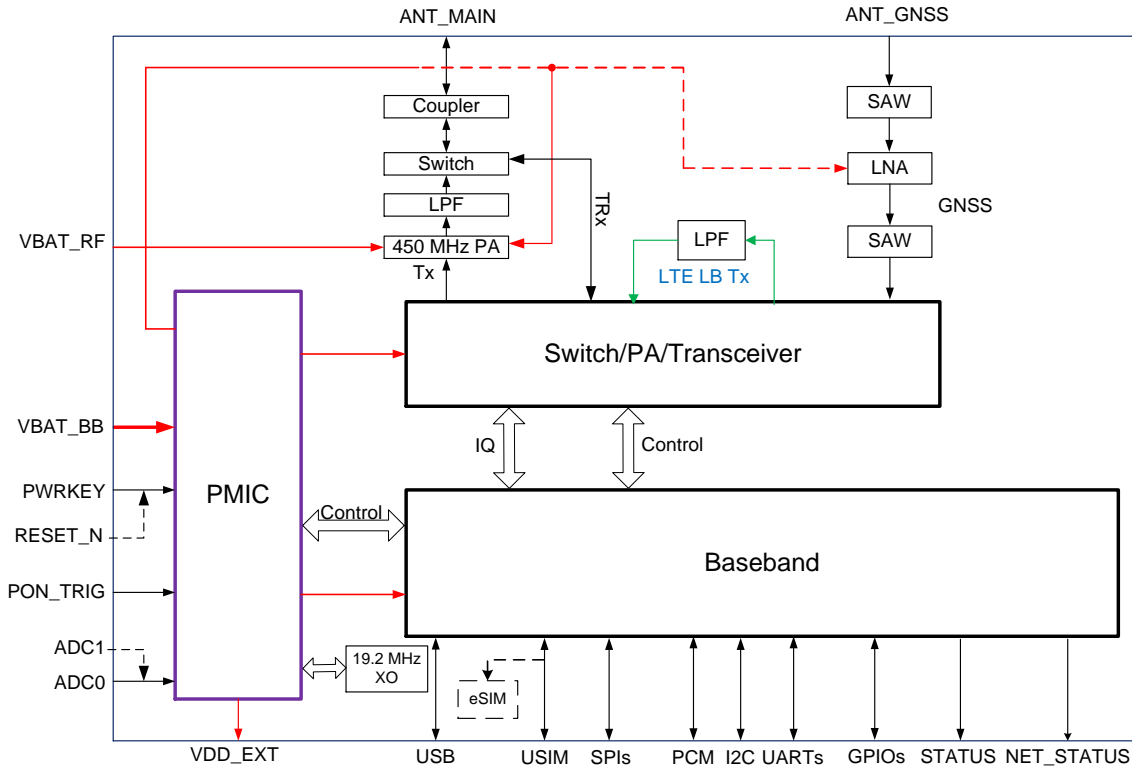

Figure 3: Functional Diagram of BG95-M4

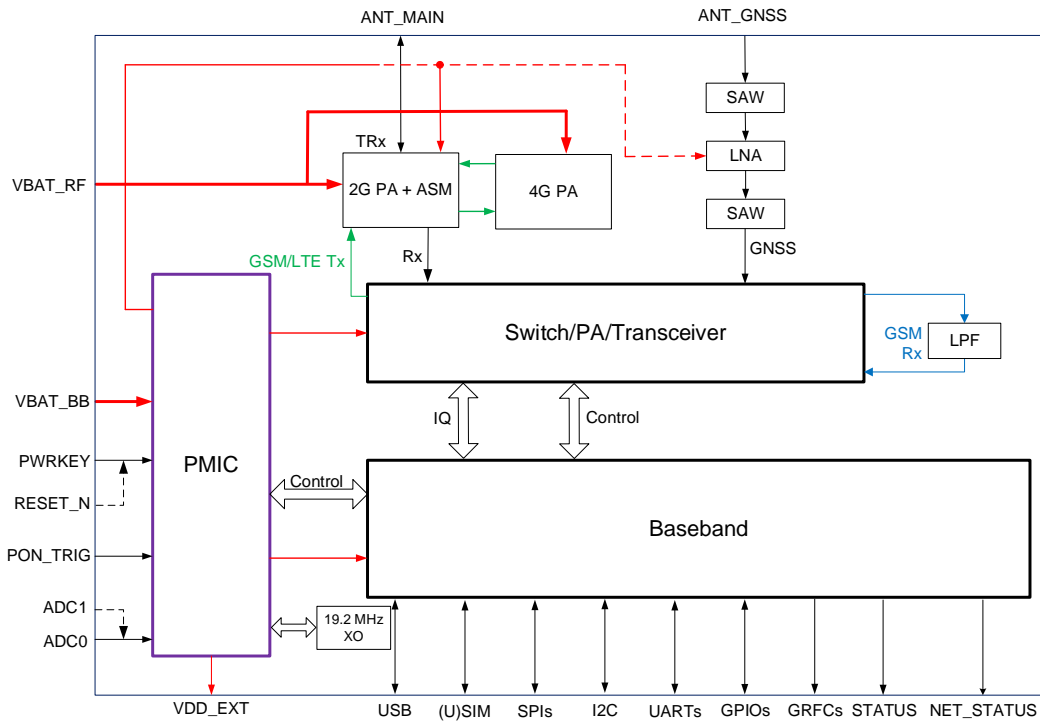

Figure 4: Functional Diagram of BG95-M5

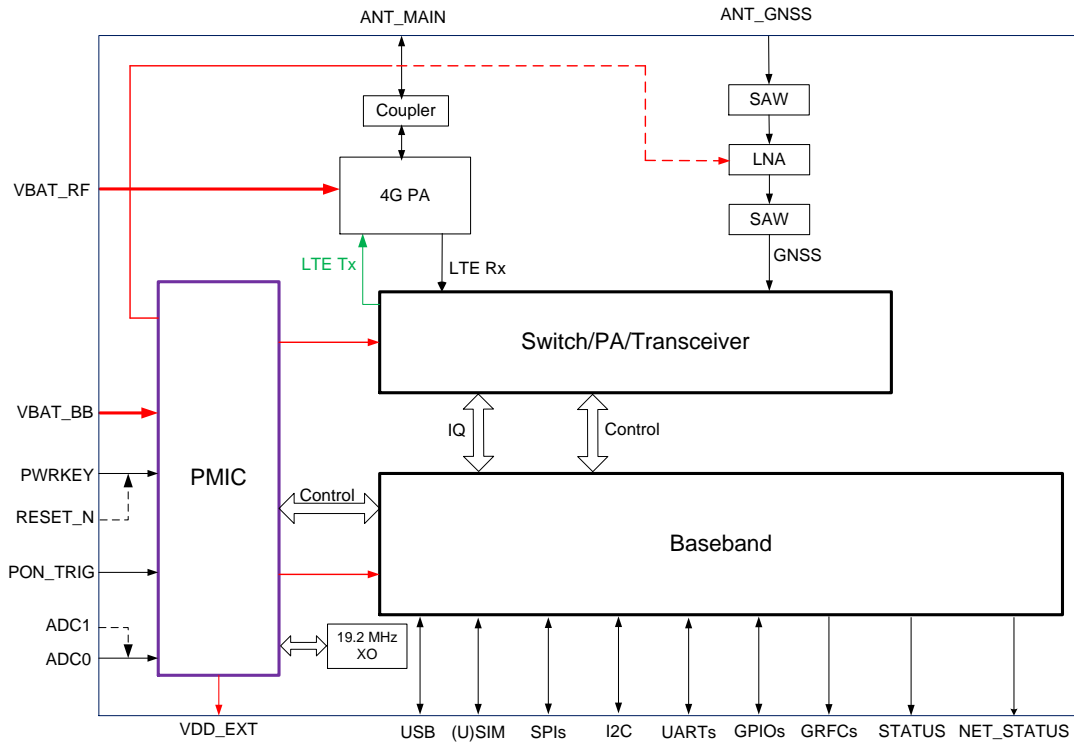

Figure 5: Functional Diagram of BG95-M6

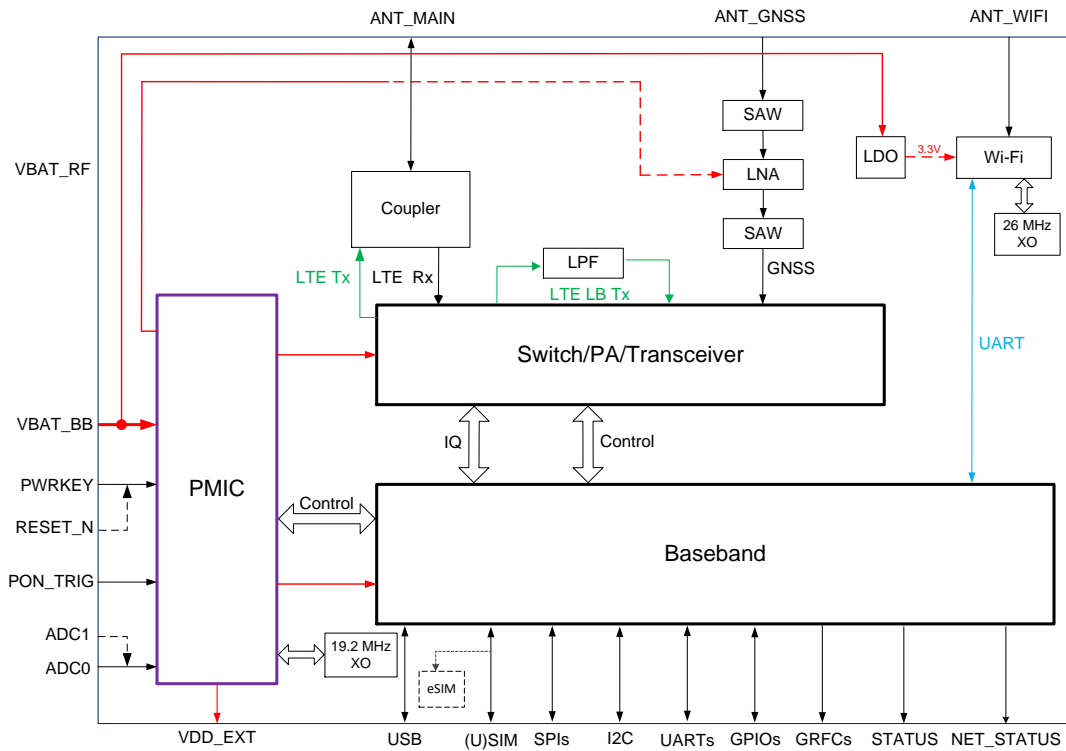

Figure 6: Functional Diagram of BG95-MF

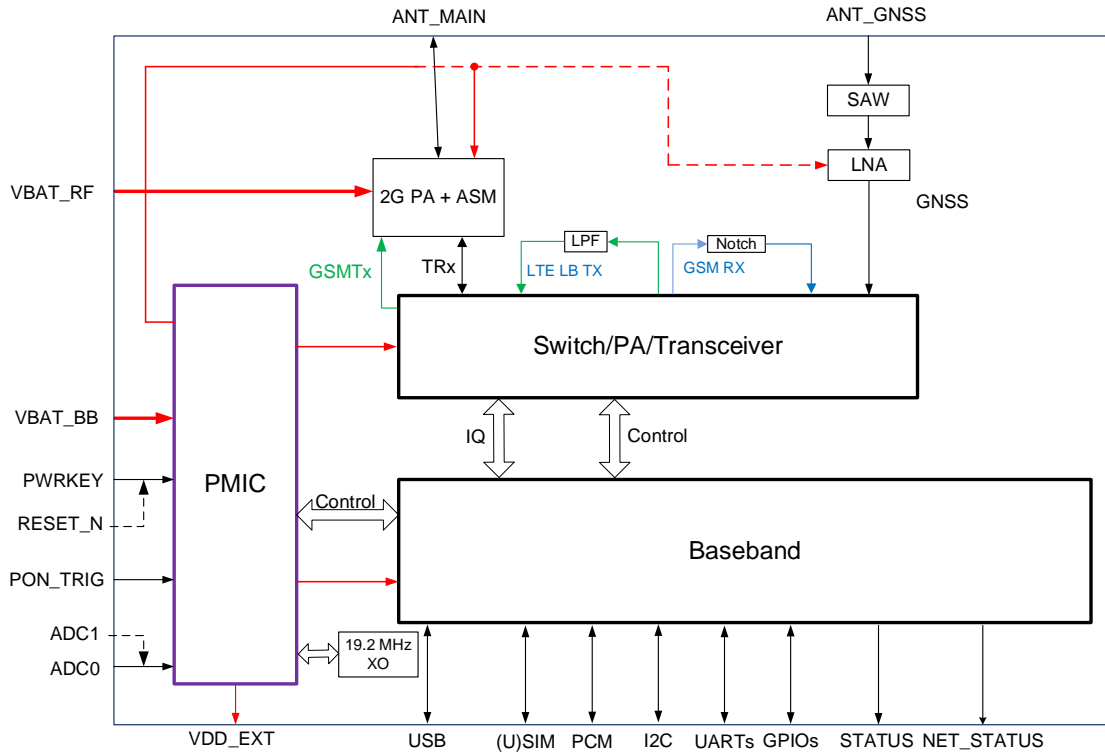

Figure 7: Functional Diagram of BG95-M8

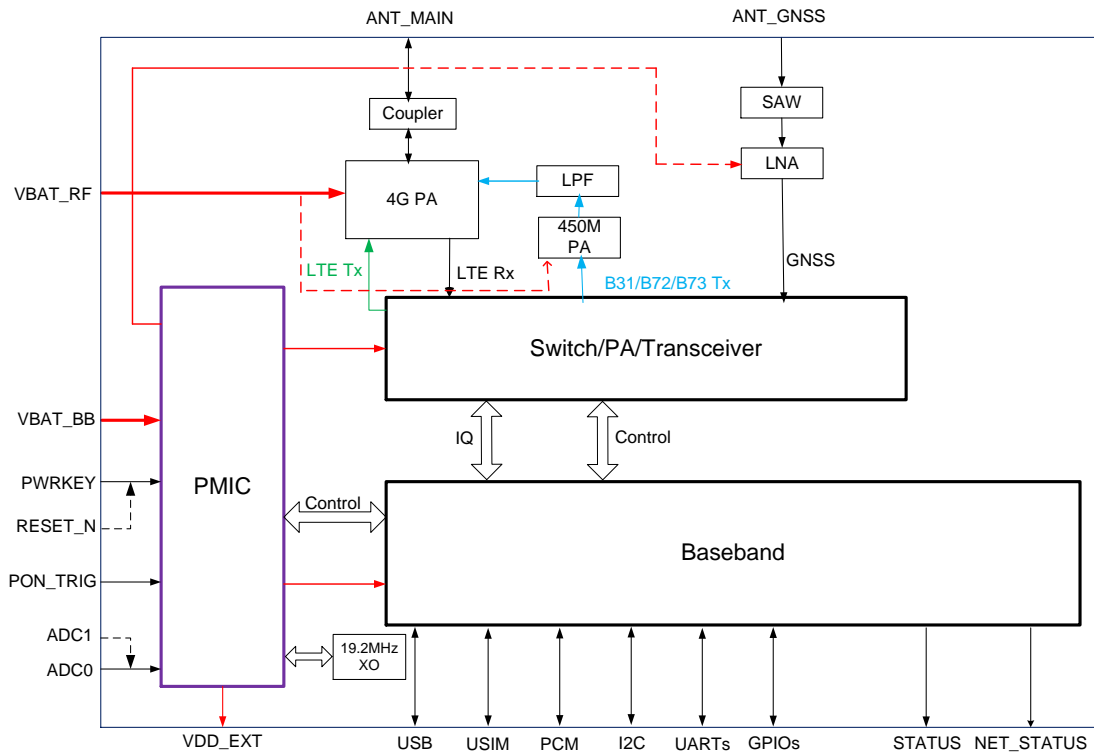

Figure 8: Functional Diagram of BG95-M9

NOTE

1. eSIM* function is optional. If eSIM is selected, then any external (U)SIM card cannot be used. BG95-M5, BG95-M6, BG95-M8 and BG95-M9 do not support eSIM.
2. The output voltage of PWRKEY is 1.5 V because of the voltage drop inside the chipset. Due to platform limitations, the chipset has integrated the reset function into PWRKEY. Therefore, never pull down PWRKEY to GND permanently.
3. RESET_N connects directly to PWRKEY inside the module.
4. Do not use ADC0 and ADC1 simultaneously, as ADC1 connects directly to ADC0 inside the module. The module supports the use of only one ADC interface at a time: either ADC0 or ADC1.

2.4. EVB Kit

To help you develop applications with the module, Quectel supplies an evaluation board (LTE OPEN EVB) with accessories to develop or test the module. For more details, see **document [2]**.

3 Application Interfaces

3.1. General Description

The module is equipped with 102 LGA pins. The subsequent chapters provide detailed descriptions of the following interfaces:

- Power supply
- PON_TRIG interface
- (U)SIM interface
- USB interface
- UART
- I2C interface
- SPI interfaces
- ADC interfaces
- MAIN_RI
- Status indication interfaces
- USB_BOOT
- GRFC interfaces

3.2. Pin Assignment

The following figure shows the pin assignment of the module.

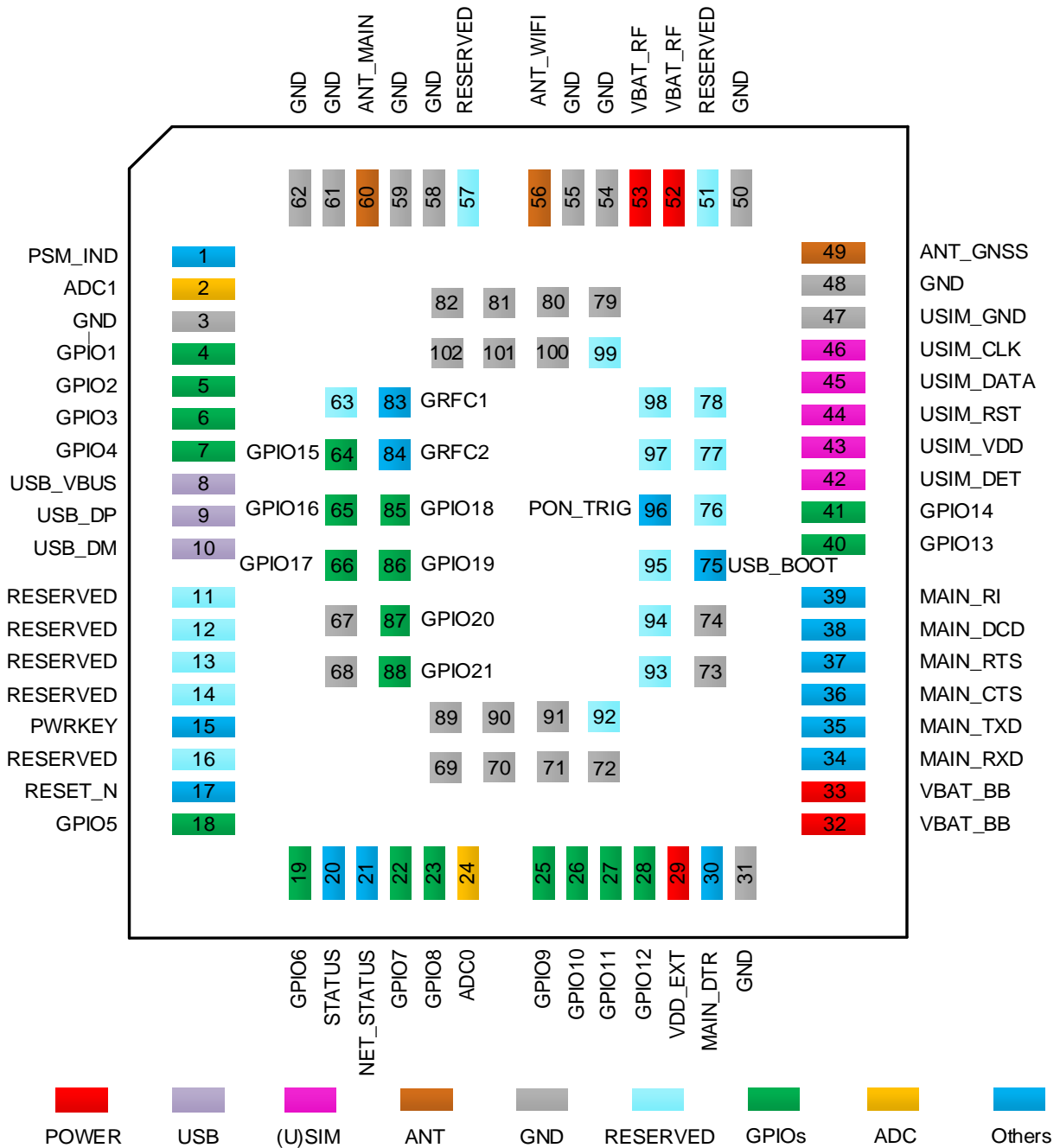

Figure 9: Pin Assignment (Top View)

NOTE

1. Only BG95-MF supports ANT_WIFI (pin 56).
2. BG95-MF does not support GPIO15 and GPIO16 interfaces (pin 64 and pin 65).
3. BG95-M4, BG95-M8 and BG95-M9 do not support GRFC interfaces (pin 83 and pin 84).
4. Do not use ADC0 and ADC1 simultaneously, as ADC1 connects directly to ADC0 inside the module. The module supports the use of only one ADC interface at a time: either ADC0 or ADC1.
5. The output voltage of PWRKEY is 1.5 V because of the voltage drop inside the chipset. Due to platform limitations, the chipset has integrated the reset function into PWRKEY. Therefore, never pull down PWRKEY to GND permanently.
6. RESET_N connects directly to PWRKEY inside the module.
7. GPIO11 (pin 27) and GRFC2 (pin 84) are BOOT_CONFIG pins. Never pull them up before startup, otherwise the module cannot turn on normally.
8. Keep all RESERVED pins and unused pins open.
9. Connect GND pins to the ground in the design.

3.3. Pin Description

Table 5: Definition of I/O Parameters

Type	Description
AI	Analog Input
AIO	Analog Input/Output
AO	Analog Output
DI	Digital Input
DIO	Digital Input/Output
DO	Digital Output
PD	Pull Down
PI	Power Input
PO	Power Output

DC characteristics include power domain and rate current.

Table 6: Pin Description

Power Supply					
Pin Name	Pin No.	I/O	Description	DC Characteristics	Comment
VBAT_BB	32, 33	PI	Power supply for the module's baseband part	BG95-M1/-M2 ⁹ : Vmax = 4.8 V Vmin = 2.6 V Vnom = 3.3 V	
VBAT_RF	52, 53	PI	Power supply for the module's RF part	BG95-M3/-M5/-M6/-MF/-M8 Vmax = 4.3 V Vmin = 3.3 V Vnom = 3.8 V BG95-M4/-M9 : Vmax = 4.2 V Vmin = 3.2 V Vnom = 3.8 V	
VDD_EXT	29	PO	Provides 1.8 V for external circuits	Vnom = 1.8 V Iomax = 50 mA	Power supply for external GPIO's pull-up circuits. If unused, keep this pin open.
GND	3, 31, 48, 50, 54, 55, 58, 59, 61, 62, 67–74, 79–82, 89–91, 100–102				
Turn On/Turn Off/Reset the Module					
Pin Name	Pin No.	I/O	Description	DC Characteristics	Comment
PWRKEY	15	DI	Turn on/off the module	Vnom = 1.5 V VILmax = 0.45 V	Never pull down PWRKEY to GND permanently. The output voltage is 1.5 V because of the voltage drop inside the chipset.
RESET_N	17	DI	Reset the module		Multiplexed from PWRKEY (connects directly to PWRKEY inside the module). If unused, keep this pin

⁹ For every VBAT transition/re-insertion from 0 V, the minimum power supply voltage should be higher than 2.7 V. After the module starts up normally, the minimum safety voltage is 2.6 V. To ensure full-function mode, the minimum power supply voltage should be higher than 2.8 V.

open.

Status Indication Interfaces

Pin Name	Pin No.	I/O	Description	DC Characteristics	Comment
PSM_IND ¹⁰	1	DO	Indicate the module's power saving mode		
STATUS	20	DO	Indicate the module's operation status	V _{OHmin} = 1.35 V V _{OLmax} = 0.45 V	1.8 V power domain. If unused, keep these pins open.
NET_STATUS	21	DO	Indicate the module's network activity status		

PON_TRIG Interface

Pin Name	Pin No.	I/O	Description	DC Characteristics	Comment
PON_TRIG	96	DI	Wake up the module from PSM		1.8 V power domain. Rising-edge triggered. Pulled-down by default. If unused, keep this pin open.

USB Interface

Pin Name	Pin No.	I/O	Description	DC Characteristics	Comment
USB_VBUS	8	AI	USB connection detect	V _{max} = 5.25 V V _{nom} = 5.0 V V _{min} = 4.0 V	Typical 5.0 V
USB_DP	9	AIO	USB differential data (+)		Compliant with USB 2.0 standard specification. Require differential impedance of 90 Ω.
USB_DM	10	AIO	USB differential data (-)		

(U)SIM Interface

Pin Name	Pin No.	I/O	Description	DC Characteristics	Comment
USIM_DET	42	DI	(U)SIM card	V _{ILmin} = -0.3 V	1.8 V power domain.

¹⁰ When PSM is enabled, the function of PSM_IND pin will be activated after the module is rebooted. When PSM_IND is in high voltage level, the module is in full functionality mode. When it is in low voltage level, the module is in PSM.

			hot-plug detect	$V_{ILmax} = 0.6\text{ V}$ $V_{IHmin} = 1.2\text{ V}$ $V_{IHmax} = 2.0\text{ V}$	If unused, keep this pin open.
USIM_VDD	43	PO	(U)SIM card power supply	$V_{max} = 1.9\text{ V}$ $V_{min} = 1.7\text{ V}$	Only 1.8 V (U)SIM card is supported.
USIM_RST	44	DO	(U)SIM card reset	$V_{OLmax} = 0.45\text{ V}$ $V_{OHmin} = 1.35\text{ V}$	1.8 V power domain.
USIM_DATA	45	DIO	(U)SIM card data	$V_{ILmin} = -0.3\text{ V}$ $V_{ILmax} = 0.6\text{ V}$ $V_{IHmin} = 1.2\text{ V}$ $V_{IHmax} = 2.0\text{ V}$ $V_{OLmax} = 0.45\text{ V}$ $V_{OHmin} = 1.35\text{ V}$	1.8 V power domain.
USIM_CLK	46	DO	(U)SIM card clock	$V_{OLmax} = 0.45\text{ V}$ $V_{OHmin} = 1.35\text{ V}$	1.8 V power domain.
USIM_GND	47	-	Specified ground for (U)SIM card		

Main UART

Pin Name	Pin No.	I/O	Description	DC Characteristics	Comment
MAIN_DTR	30	DI	Main UART data terminal ready	$V_{ILmin} = -0.3\text{ V}$ $V_{ILmax} = 0.6\text{ V}$	1.8 V power domain. If unused, keep these pins open.
MAIN_RXD	34	DI	Main UART receive	$V_{IHmin} = 1.2\text{ V}$ $V_{IHmax} = 2.0\text{ V}$	
MAIN_TXD	35	DO	Main UART transmit	$V_{OLmax} = 0.45\text{ V}$ $V_{OHmin} = 1.35\text{ V}$	
MAIN_CTS	36	DO	Clear to send signal from the module	$V_{OLmax} = 0.45\text{ V}$ $V_{OHmin} = 1.35\text{ V}$	Connect to the MCU's CTS. 1.8 V power domain. If unused, keep the pin open.
MAIN_RTS	37	DI	Request to send signal to the module	$V_{ILmin} = -0.3\text{ V}$ $V_{ILmax} = 0.6\text{ V}$ $V_{IHmin} = 1.2\text{ V}$ $V_{IHmax} = 2.0\text{ V}$	Connect to the MCU's RTS. 1.8 V power domain. If unused, keep the pin open.
MAIN_DCD	38	DO	Main UART data carrier detect	$V_{OLmax} = 0.45\text{ V}$ $V_{OHmin} = 1.35\text{ V}$	1.8 V power domain. If unused, keep these pins open.
MAIN_RI	39	DO	Main UART ring indication		

ADC Interfaces

Pin Name	Pin No.	I/O	Description	DC Characteristics	Comment
ADC1	2	AI	General-purpose ADC interface	Voltage range: 0.1–1.8 V	Do not use ADC0 and ADC1 simultaneously, as ADC1 connects directly to ADC0 inside the module. If unused, Keep these pins open.
ADC0	24	AI	General-purpose ADC interface		

USB_BOOT Interface

Pin Name	Pin No.	I/O	Description	DC Characteristics	Comment
USB_BOOT	75	DI	Force the module into emergency download mode	$V_{ILmin} = -0.3\text{ V}$ $V_{ILmax} = 0.6\text{ V}$ $V_{IHmin} = 1.2\text{ V}$ $V_{IHmax} = 2.0\text{ V}$	1.8 V power domain. If unused, keep this pin open.

Antenna Interfaces

Pin Name	Pin No.	I/O	Description	DC Characteristics	Comment
ANT_MAIN	60	AIO	Main antenna interface		50 Ω impedance.
ANT_WIFI	56	AI	Wi-Fi antenna interface		50 Ω impedance. If unused, keep this pin open. Only BG95-MF supports the interface.
ANT_GNSS	49	AI	GNSS antenna interface		50 Ω impedance. If unused, keep this pin open.

GPIO Interfaces

Pin Name	Pin No.	I/O	Description	DC Characteristics	Comment
GPIO1	4	DIO	General-purpose input/output	$V_{OLmax} = 0.45\text{ V}$ $V_{OHmin} = 1.35\text{ V}$ $V_{ILmin} = -0.3\text{ V}$ $V_{ILmax} = 0.6\text{ V}$ $V_{IHmin} = 1.2\text{ V}$ $V_{IHmax} = 2.0\text{ V}$	1.8 V power domain. If unused, keep these pins open.
GPIO2	5	DIO			
GPIO3	6	DIO			
GPIO4	7	DIO			
GPIO5	18	DIO			

GPIO6	19	DIO	General-purpose input/output	$V_{OLmax} = 0.45\text{ V}$ $V_{OHmin} = 1.35\text{ V}$ $V_{ILmin} = -0.3\text{ V}$ $V_{ILmax} = 0.6\text{ V}$ $V_{IHmin} = 1.2\text{ V}$ $V_{IHmax} = 2.0\text{ V}$	1.8 V power domain. If unused, keep these pins open.
GPIO7	22	DIO			
GPIO8	23	DIO			
GPIO9	25	DIO			
GPIO10	26	DIO			
GPIO11	27	DIO	General-purpose input/output	$V_{OLmax} = 0.45\text{ V}$ $V_{OHmin} = 1.35\text{ V}$ $V_{ILmin} = -0.3\text{ V}$ $V_{ILmax} = 0.6\text{ V}$ $V_{IHmin} = 1.2\text{ V}$ $V_{IHmax} = 2.0\text{ V}$	1.8 V power domain. If unused, keep these pins open.
GPIO12	28	DIO			
GPIO13	40	DIO			
GPIO14	41	DIO			
GPIO15 ¹¹	64	DIO			
GPIO16 ¹¹	65	DIO	General-purpose input/output	$V_{OLmax} = 0.45\text{ V}$ $V_{OHmin} = 1.35\text{ V}$ $V_{ILmin} = -0.3\text{ V}$ $V_{ILmax} = 0.6\text{ V}$ $V_{IHmin} = 1.2\text{ V}$ $V_{IHmax} = 2.0\text{ V}$	1.8 V power domain. If unused, keep these pins open.
GPIO17	66	DIO			
GPIO18	85	DIO			
GPIO19	86	DIO			
GPIO20	87	DIO			
GPIO21	88	DIO			

GRFC Interfaces ¹²

Pin Name	Pin No.	I/O	Description	DC Characteristics	Comment
GRFC1	83	DO	Generic RF controller	$V_{OLmax} = 0.45\text{ V}$ $V_{OHmin} = 1.35\text{ V}$	1.8 V power domain. If unused, keep this pin open.
GRFC2	84	DO	Generic RF controller	$V_{OLmax} = 0.45\text{ V}$ $V_{OHmin} = 1.35\text{ V}$	BOOT_CONFIG Do not pull it up before startup. 1.8 V power domain. If unused, keep this pin open.

¹¹ BG95-MF does not support GPIO15 and GPIO16 interfaces (pin 64 and pin 65).

¹² BG95-M4, BG95-M8 and BG95-M9 do not support GRFC interfaces (pin 83 and pin 84).

RESERVED Pins

Pin Name	Pin Number	Comment
RESERVED	11–14, 16, 51, 57, 63, 76–78, 92–95, 97–99	Keep these pins open.

NOTE

1. The output voltage of PWRKEY is 1.5 V because of the voltage drop inside the chipset. Due to platform limitations, the chipset has integrated the reset function into PWRKEY. Therefore, never pull down PWRKEY to GND permanently.
2. RESET_N connects directly to PWRKEY inside the module.
3. Do not use ADC0 and ADC1 simultaneously, as ADC1 connects directly to ADC0 inside the module. The module supports the use of only one ADC interface at a time: either ADC0 or ADC1.
4. When PSM is enabled, the function of PSM_IND pin will be activated after the module is rebooted. When PSM_IND is at high voltage level, the module is in full functionality mode, when it is at a low voltage level, the module is in PSM.
5. GPIO11 (pin 27) and GRFC2 (pin 84) are BOOT_CONFIG pins. Never pull them up before startup, otherwise the module cannot turn on normally.
6. Keep all RESERVED and unused pins open.
7. Connect GND to ground in the design.

3.4. Pin Multiplexing Assignment

Table 7: Multiplexing Pins

Pin Name	Pin No.	Function 1	Function 2	Function 3	Function 4	Reset	Interrupt Wakeup	Comment
GPIO1	4	GPIO_24	-	-	-	PD	-	
GPIO2	5	GPIO_21	-	-	-	PD	√	
GPIO3	6	GPIO_22	-	-	-	PD	√	
GPIO4	7	GPIO_23	-	-	-	PD	-	
GPIO5	18	GPIO_3	-	-	I2C1_SCL	PD	-	
GPIO6	19	GPIO_2	-	-	I2C1_SDA	PD	√	
GPIO7	22	GPIO_1	UART1_	-	-	PD	√	

			RXD					
GPIO8	23	GPIO_0	UART1_TXD	-	-	PD	√	
GPIO9	25	GPIO_6	-	SPI1_CS_N	-	PD	√	
GPIO10	26	GPIO_7	-	SPI1_CLK	-	PD	-	
GPIO11	27	GPIO_4	UART3_TXD	SPI1_MOSI	-	PD	√	BOOT_CONFIG
GPIO12	28	GPIO_5	UART3_RXD	SPI1_MISO	-	PD	√	
GPIO13	40	GPIO_15	-	SPI2_CLK	-	PD	-	
GPIO14	41	GPIO_14	-	SPI2_CS_N	-	PD	√	
GPIO15 ¹¹	64	GPIO_12	UART2_TXD	SPI2_MOSI	-	PD	-	
GPIO16 ¹¹	65	GPIO_13	UART2_RXD	SPI2_MISO	-	PD	√	
GPIO17	66	GPIO_50	PWM	-	-	PD	√	
GPIO18	85	GPIO_52	-	-	-	PD	√	
GPIO19	86	GPIO_36	-	-	-	PD	√	
GPIO20	87	GPIO_40	-	-	-	PD	-	
GPIO21	88	GPIO_41	-	-	-	PD	-	

NOTE

1. The pin functions 1/2/3/4 take effect only after software configuration.
2. The BOOT_CONFIG pin (pin 27) cannot be pulled up before startup, otherwise the module cannot turn on normally.
3. “√” means “supported” while “-” means “not supported”.

Table 8: Pull-up/Pull-down Resistance of GPIOs

Symbol	Description	Min.	Max.	Unit
R _{PU}	Pull-up resistance	55	390	kΩ
R _{PD}	Pull-down resistance	55	390	kΩ

3.5. Operating Modes

Table 9: Overview of Operating Modes

Mode	Details	
Full Functionality Mode	Connected	The module is connected to network. Its power consumption varies with the network setting and data transfer rate.
	Idle	The module remains registered on network, and is ready to send and receive data. In this mode, the software is active.
Extended Idle Mode DRX (e-I-DRX)	The module and the network may negotiate over non-access stratum signaling the use of e-I-DRX for reducing power consumption, while being available for mobile terminating data and/or network originated procedures within a certain delay dependent on the DRX cycle value.	
Airplane Mode	AT+CFUN=4 can set the module into airplane mode where the RF function is invalid.	
Minimum Functionality Mode	AT+CFUN=0 can set the module into a minimum functionality mode without removing the power supply. In this mode, both RF function and (U)SIM card are invalid.	
Sleep Mode	The module remains the ability to receive paging message, SMS and TCP/UDP data from the network normally. In this mode, the power consumption is reduced to a low level.	
Power OFF Mode	The module's power supply is shut down by its power management unit. In this mode, the software is inactive, the serial interfaces are inaccessible, while the operating voltage (connected to VBAT_RF and VBAT_BB) remains applied.	
Power Saving Mode (PSM)	PSM is similar to turn-off, but the module remains registered on the network and there is no need to re-attach or re-establish PDN connections. The power consumption is reduced to a minimized level.	

NOTE

During e-I-DRX, it is recommended to use UART for data communication, as the use of USB interface will increase power consumption.

3.6. Power Saving

3.6.1. Airplane Mode

When the module enters airplane mode, the RF function does not work, and all AT commands correlative with RF function are inaccessible. This mode can be set via the following AT command.

AT+CFUN=<fun> provides choice of the functionality level, through setting **<fun>** into 0, 1 or 4.

- **AT+CFUN=0**: Minimum functionality mode. Both (U)SIM and RF functions are disabled.
- **AT+CFUN=1**: Full functionality mode (by default).
- **AT+CFUN=4**: Airplane mode. RF function is disabled.

NOTE

The execution of **AT+CFUN** will not affect GNSS function. For more details, see **document [3]**.

3.6.2. Power Saving Mode (PSM)

The module minimizes its power consumption through entering PSM. The mode is similar to power-off, but the module remains registered on the network and there is no need to re-attach or re-establish PDN connections. Therefore, the module in PSM cannot immediately respond to users' requests.

When the module wants to use the PSM, it shall request an Active Time value during every Attach and TAU procedures. If the network supports PSM and accepts that the module uses PSM, the network confirms usage of PSM by allocating an Active Time value to the module. If the module wants to change the Active Time value, e.g., the module requests the value it wants in the TAU procedure.

If PSM is supported by the network, then it can be enabled via *qapi_QT_NW_PSM_Cfg_Set()*. See **document [4]** for details about the API function.

Any of the following methods can wake up the module from PSM:

- Wake up the module from PSM through a rising edge on PON_TRIG. (Recommended)
- Wake up the module by driving PWRKEY low.
- When the TAU timer expires, the module wakes up from PSM automatically.

3.6.3. Extended Idle Mode DRX (e-I-DRX)

The module (UE) and the network may negotiate over non-access stratum signalling the use of e-I-DRX for reducing its power consumption, while being available for mobile terminating data and/or network originated procedures within a certain delay dependent on the DRX cycle value.

Applications that want to use e-I-DRX need to consider specific handling of mobile terminating services or data transfers, and in particular they need to consider the delay tolerance of mobile terminated data.

In order to negotiate the use of e-I-DRX, the UE requests e-I-DRX parameters during attach procedure and RAU/TAU procedure. The EPC may reject or accept the UE request for enabling e-I-DRX. In case the EPC accepts e-I-DRX, the EPC based on operator policies and, if available, the e-I-DRX cycle length value in the subscription data from the HSS, may also provide different values of the e-I-DRX parameters than what were requested by the UE. If the EPC accepts the use of e-I-DRX, the UE applies e-I-DRX based on the received e-I-DRX parameters. If the UE does not receive e-I-DRX parameters in the relevant accept message because the EPC rejected its request or because the request was received by EPC not supporting e-I-DRX, the UE shall apply its regular discontinuous reception.

If e-I-DRX is supported by the network, then it can be enabled by `qapi_QT_NW_eDRX_Cfg_Set()`. See **document [4]** for details about the API function.

3.6.4. Sleep Mode

The module lowers the power consumption in sleep mode. The following sub-chapters describe the power saving procedure of the module.

3.6.4.1. UART Application

If the MCU communicates with the module via the main UART, the following preconditions enable the module to enter sleep mode.

- Execute `qapi_QT_QSCLK_Enable_Set()` to enable sleep mode. See **document [4]** for details about the API function.
- Drive MAIN_DTR high.

The following figure shows the connection between the module and the MCU.

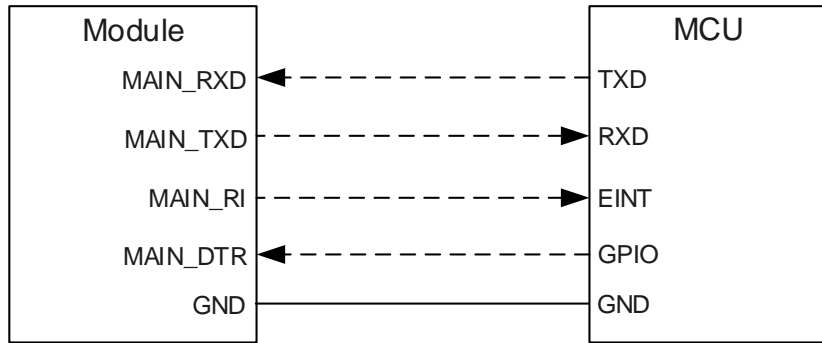

Figure 10: Sleep Mode Application via UART

- When the module has a URC to report, MAIN_RI will wake up the MCU. See **Chapter 3.17** for details about MAIN_RI behavior.
- Driving MAIN_DTR low will wake up the module.

3.7. Power Supply

3.7.1. Power Supply Pins

The module provides the following four VBAT pins for connection with an external power supply. There are two separate voltage domains for VBAT.

- Two VBAT_RF pins for the module’s RF part.
- Two VBAT_BB pins for the module’s baseband part.

Table 10: VBAT and GND Pins

Pin Name	Pin No.	IO	Description	Module	Min.	Typ.	Max.	Unit
VBAT_RF	52, 53	PI	Power supply for the module’s RF part	BG95-M1/-M2	2.6	3.3	4.8	V
				BG95-M3/-M5/-M6/-MF/-M8	3.3	3.8	4.3	V
				BG95-M4/-M9	3.2	3.8	4.2	V
VBAT_BB	32, 33	PI	Power supply for the module’s baseband part	BG95-M1/-M2	2.6	3.3	4.8	V
				BG95-M3/-M5/-M6/-MF/-M8	3.3	3.8	4.3	V

	BG95-M4/-M9	3.2	3.8	4.2	V
GND	3, 31, 48, 50, 54, 55, 58, 59, 61, 62, 67–74, 79–82, 89–91, 100–102				

3.7.2. Voltage Stability Requirements

- BG95-M1/-M2:**
 The power supply range of BG95-M1/-M2 is 2.6–4.8 V. For every VBAT transition/re-insertion from 0 V, the minimum power supply voltage should be higher than 2.7 V. After the module starts up normally, the minimum safety voltage is 2.6 V. To ensure full functionality mode, the minimum power supply voltage should be higher than 2.8 V. Make sure that the input voltage never drops below 2.6 V.
- BG95-M3/-M5/-M6/-MF/-M8:**
 The power supply range of BG95-M3/-M5/-M6/-MF/-M8 is 3.3–4.3 V. Ensure the input voltage never drop below 3.3 V.
- BG95-M4/-M9:**
 The power supply range of BG95-M4/-M9 is from 3.2–4.2 V. Ensure the input voltage never drops below 3.2 V.

The following figure shows the voltage drop during burst transmission in 2G network of BG95-M3/-M5/-M8. The voltage drop is less in LTE Cat M1 and/or LTE Cat NB2 networks.

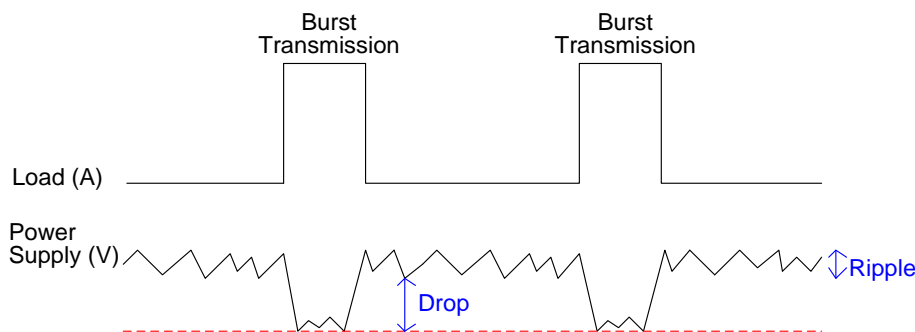

Figure 11: Power Supply Limits During Burst Transmission (BG95-M3/-M5/-M8)

To decrease voltage-drop, bypass capacitors of about 100 μ F with low ESR should be used, and multi-layer ceramic chip capacitor (MLCC) arrays should also be reserved due to their low ESR. Use seven ceramic capacitors (220 nF, 47 nF, 150 pF, 100 pF, 68 pF, 33 pF, 10 pF) to compose the MLCC array for VBAT_BB, three ceramic capacitors (100 nF, 33 pF, 10 pF) to compose the MLCC array for VBAT_RF, and place these capacitors close to VBAT pins. The main power supply from an external application has to be a single voltage source and can be expanded to two sub paths with star structure. The width of

VBAT_BB trace should be not less than 0.6 mm, and the width of VBAT_RF trace should be not less than 2.7 mm. The longer the VBAT trace is, the wider it should be.

To get a stable power supply, it is suggested to use two TVS components with low leakage current and suitable reverse stand-off voltage, and it is recommended to place them as close as possible to the VBAT pins.

In addition, route VBAT_BB and VBAT_RF traces in inner-layer of the PCB, and place a ferrite bead as close to VBAT_BB as possible. Follow the criteria below for ferrite bead selection:

- Current rating ≥ 600 mA and lower DC resistance to avoid voltage drop during instantaneous high-power consumption.
- $\geq 800 \Omega$ impedance @ 700–960 MHz.

The following figure shows the star structure of the power supply.

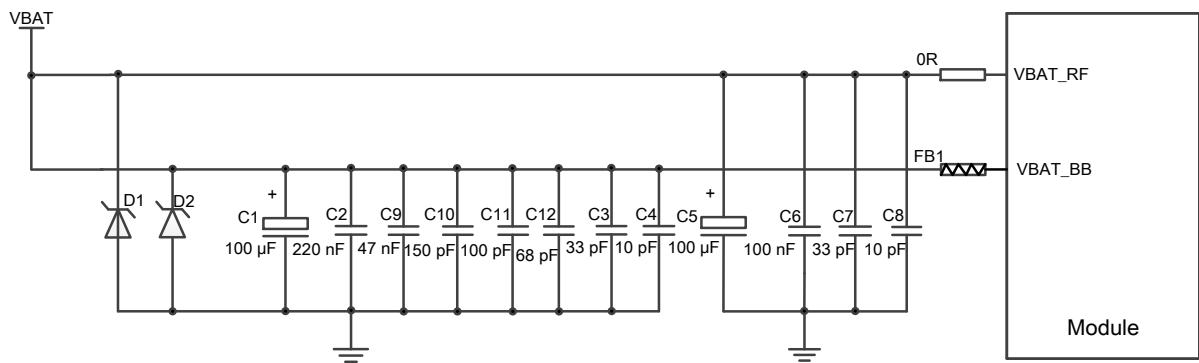

Figure 12: Star Structure of the Power Supply

If only LTE Cat M1 and/or Cat NB2 networks are intended to be used, it is recommended to select a DC-DC converter chip or LDO chip with ultra-low leakage current and current output not less than 1.0 A for the power supply design.

If LTE Cat M1, Cat NB2 and EGPRS networks are all used, the current output of DC-DC converter chip or LDO chip should exceed 2.7 A and power supply chips with low leakage current should be adopted because the module needs higher current in GSM network transmission. Only BG95-M3, BG95-M5 and BG95-M8 support GSM network. For more details about the supported bands of each module model, see **Table 3**.

3.7.3. Power Supply Voltage Monitoring

AT+CBC can be used to monitor the VBAT_BB voltage value. For more details, see **document [3]**.

3.8. Turn On and Off

3.8.1. Turn On with PWRKEY

Table 11: PWRKEY Pin Definition

Pin Name	Pin No.	IO	Description	Comment
PWRKEY	15	DI	Turn on/off the module	The output voltage is 1.5 V because of the voltage drop inside the chipset.

The module can be turned on from the turned-off state by driving PWRKEY low for 500–1000 ms. It is recommended to use an auto turn-on circuit to control PWRKEY, as shown below.

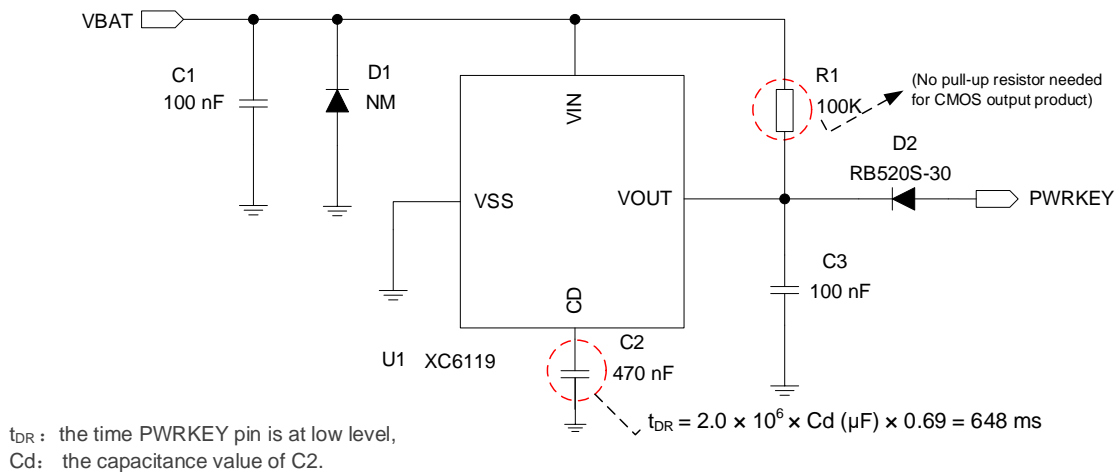

Figure 13: Auto Turn-On Circuit

Visit <https://www.torexsemi.com/> for more information on the XC6119 voltage detector.

NOTE

With the above circuit, the module automatically turns on and keeps the PWRKEY at a high level as soon as the power supply is switched on. When the module has been turned off by the API but needs to be turned on again, the power supply should be switched off and remain in the switch-off state for at least 200 ms before switched on to enable the module to turn on automatically.

If the device has an extra MCU, it is recommended to use an open drain/collector driver to control the PWRKEY. A simple reference design is illustrated in the following figure.

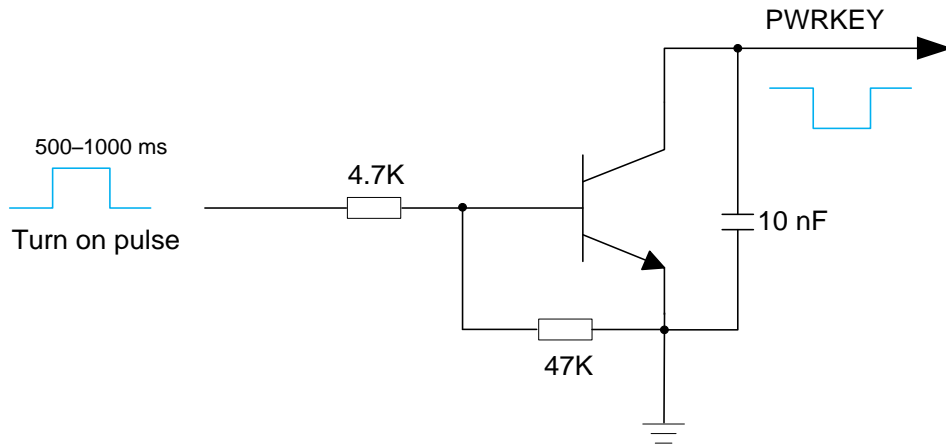

Figure 14: Turn On with a Driver Circuit

Another way to control the PWRKEY is to use a push button. As electrostatic strike may be generated from the finger touching when the button is pressed, a TVS is indispensable to be placed near the button for ESD protection. A reference design is shown in the following figure.

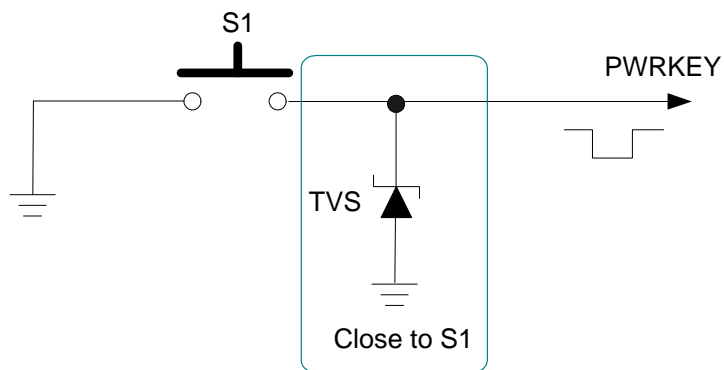

Figure 15: Turn on the Module with a Push Button

The power-up timing is illustrated in the following figure.

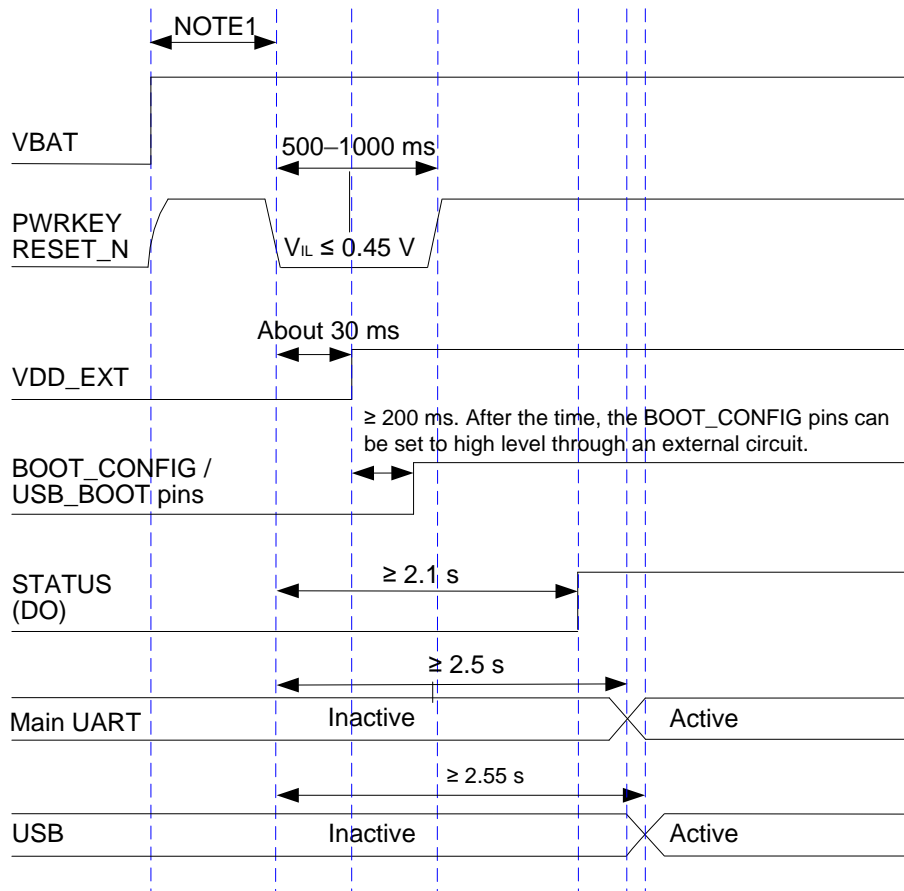

Figure 16: Power-up Timing

NOTE

1. Ensure VBAT is stable before pulling down PWRKEY and keep the interval not less than 30 ms.
2. The output voltage of PWRKEY is 1.5 V because of the voltage drop inside the chipset. Due to platform limitations, the chipset has integrated the reset function into PWRKEY. Therefore, never pull down PWRKEY to GND permanently.

3.8.2. Turn Off

Either method below can be used to turn off the module normally:

- Turn off the module with PWRKEY.
- Turn off the module with API.

3.8.2.1. Turn Off with PWRKEY

Drive PWRKEY low for 650–1500 ms, then release it and the module will execute power-down procedure.

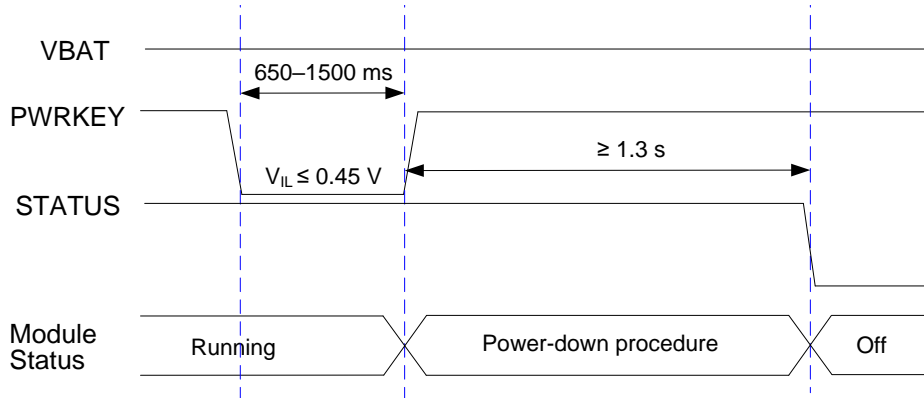

Figure 17: Power-down Timing

3.8.2.2. Turn Off with API

It is also a safe way to turn off the module with `qapi_QT_Shutdown_Device()`, which is similar to turning off the module with PWRKEY. See **document [4]** for details about the API function.

NOTE

1. To avoid corrupting the data in the internal flash, do not switch off the power supply when the module works normally. Only after the module is turned off with PWRKEY or API can the power supply be switched off.
2. While turning off the module with API, keep PWRKEY at a high level after the execution of turn-off command. Otherwise, the module will be turned on again after it turns off.
3. It is recommended to judge whether the module has shut down based on the state of the STATUS.

3.9. Reset

RESET_N is used to reset the module. Due to platform limitations, the chipset has integrated the reset function into PWRKEY, and RESET_N connects directly to PWRKEY inside the module.

The module can be reset by driving RESET_N low for 2–3.8 s.

Table 12: Pin Definition of RESET_N

Pin Name	Pin No.	I/O	Description	Comment
RESET_N	17	DI	Reset the module	Multiplexed from PWRKEY (connects directly to PWRKEY inside the module).

The recommended circuit is similar to the PWRKEY control circuit. An open drain/collector driver or a push button can be used to control RESET_N.

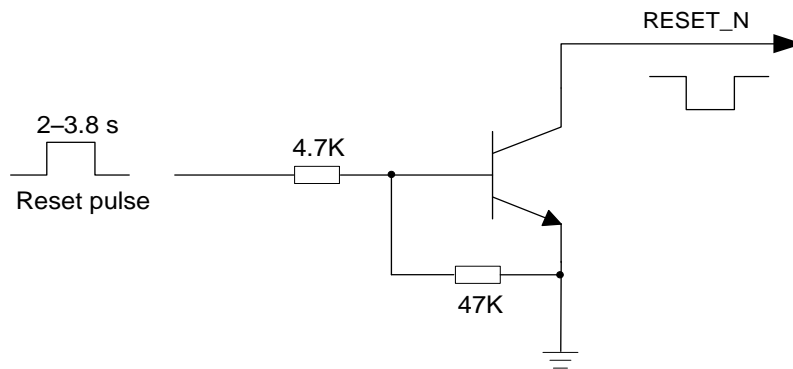

Figure 18: A Reference Design of RESET_N with a Driver Circuit

Another way to control the RESET_N is to use a push button.

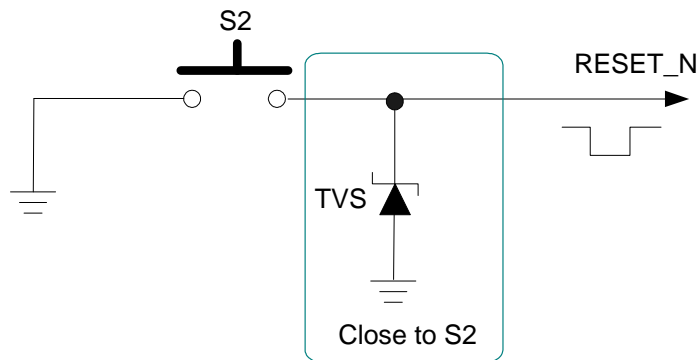

Figure 19: A Reference Design of RESET_N with a Push Button

The reset timing is illustrated in the following figure.

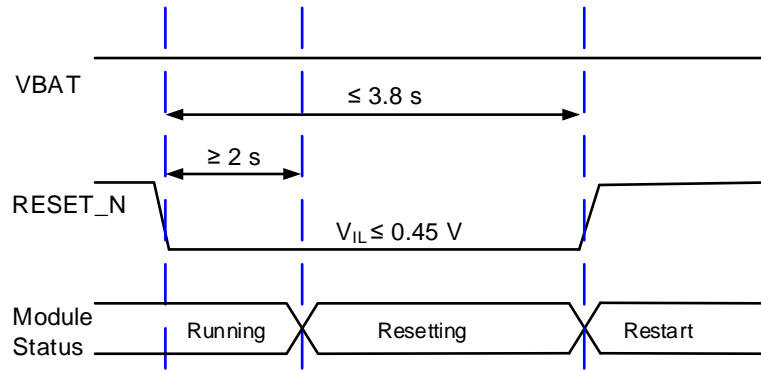

Figure 20: Reset Timing

NOTE

Ensure that there is no large capacitance on RESET_N.

3.10. PON_TRIG Interface

The module provides one PON_TRIG pin to wake up the module from PSM. When the pin detects a rising edge and keep a high level for at least 30 ms, the module wakes up from PSM.

Table 13: Pin Definition of PON_TRIG Interface

Pin Name	Pin No.	I/O	Description	Comment
PON_TRIG	96	DI	Wake up the module from PSM	Rising-edge triggered. Pulled-down by default. 1.8 V power domain. If unused, keep this pin open.

A reference design is shown in the following figure.

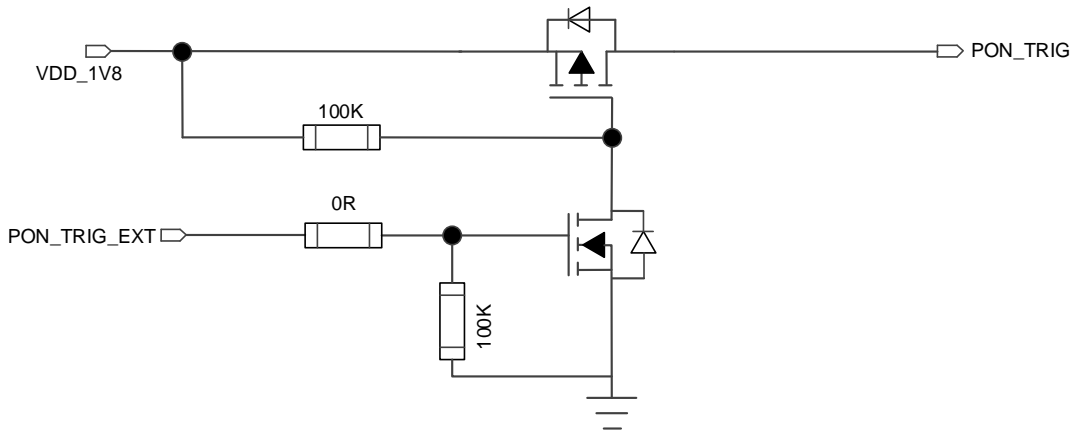

Figure 21: A Reference Design of PON_TRIG

NOTE

VDD_1V8 is powered by an external LDO.

3.11. (U)SIM Interface

The module supports 1.8 V (U)SIM card only. The (U)SIM interface circuitry meets ETSI and IMT-2000 requirements.

Table 14: Pin Definition of (U)SIM Interface

Pin Name	Pin No.	I/O	Description	Comment
USIM_DET	42	DI	(U)SIM card hot-plug detect	1.8 V power domain. If unused, keep this pin open.
USIM_VDD	43	PO	(U)SIM card power supply	Only 1.8 V (U)SIM card is supported.
USIM_RST	44	DO	(U)SIM card reset	
USIM_DATA	45	DIO	(U)SIM card data	1.8 V power domain.
USIM_CLK	46	DO	(U)SIM card clock	
USIM_GND	47		Specified ground for (U)SIM card	

The module supports (U)SIM card hot-plug via USIM_DET, and both high-level and low-level detections are supported. The function is disabled by default, and see **AT+QSIMDET** in **document [3]** for more details.

The following figure shows a reference design of (U)SIM interface with an 8-pin (U)SIM card connector.

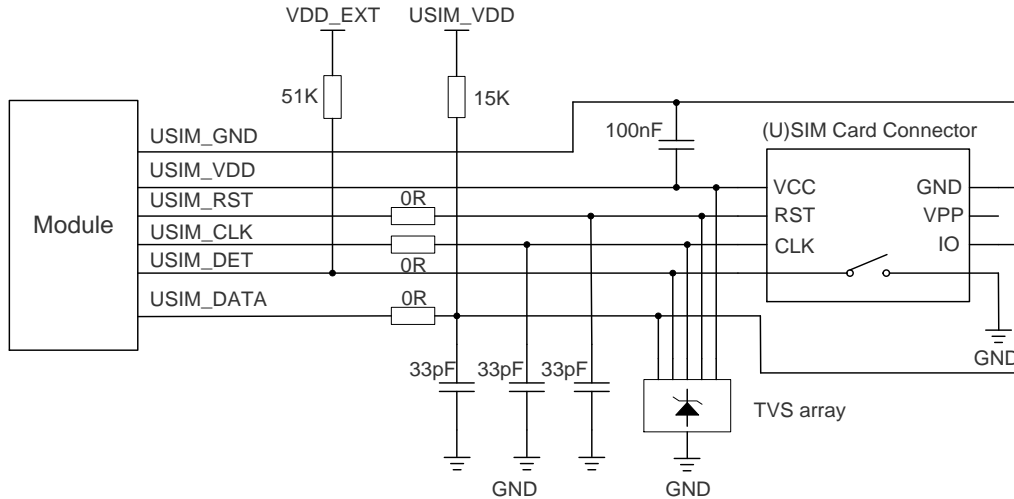

Figure 22: A Reference Design of (U)SIM Interface with an 8-Pin (U)SIM Card Connector

If (U)SIM card detection function is not needed, keep USIM_DET open. A reference design for (U)SIM interface with a 6-pin (U)SIM card connector is illustrated in the following figure.

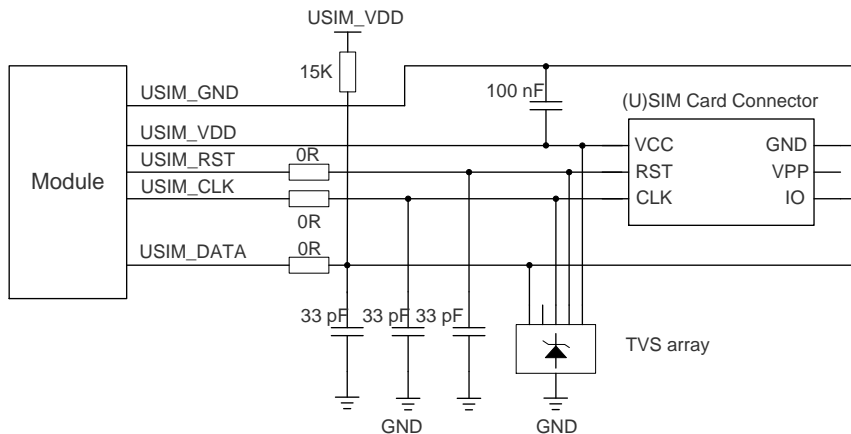

Figure 23: A Reference Design of (U)SIM Interface with a 6-Pin (U)SIM Card Connector

To enhance the reliability and availability of the (U)SIM card in applications, follow the criteria below in (U)SIM circuit design:

- Keep the placement of (U)SIM card connector as close to the module as possible. Keep the trace length as short as possible, at most 200 mm.

- Keep (U)SIM card signals away from RF and power supply traces.
- Assure the ground trace between the module and the (U)SIM card connector short and wide. Keep the trace width of ground and USIM_VDD not less than 0.5 mm to maintain the same electric potential. Make sure the bypass capacitor between USIM_VDD and USIM_GND is less than 1 μ F, and place it as close to (U)SIM card connector as possible. If the system ground plane is complete, USIM_GND can be connected to the system ground directly.
- To avoid crosstalk between USIM_DATA and USIM_CLK, keep them away from each other and shield them with surrounded ground. USIM_RST should also be surrounded with ground.
- To offer good ESD protection, it is recommended to add a TVS array with parasitic capacitance not exceeding 15 pF. To facilitate debugging, it is recommended to reserve series resistors for the (U)SIM signals of the module. The 33 pF capacitors are used for RF filtering interference. Note that the (U)SIM peripheral circuit should be close to the (U)SIM card connector.
- The pull-up resistor on USIM_DATA trace can improve anti-jamming capability when long layout trace and sensitive occasion are applied, and should be placed close to the (U)SIM card connector.

NOTE

1. eSIM* function is optional. If eSIM is selected, then the external (U)SIM card cannot be used simultaneously.
2. BG95-M5, BG95-M6, BG95-M8 and BG95-M9 do not support eSIM.

3.12. USB Interface

The module provides one integrated USB interface which complies with the USB 2.0 specification and supports operation at high-speed (480 Mbps), low-speed (1.5 Mbps) and full-speed (12 Mbps) modes.

The USB interface is used for AT command communication, data transmission ¹³, GNSS NMEA sentences output, software debugging and firmware upgrade. The following table shows the pin definition of USB interface.

Table 15: Pin Definition of USB Interface

Pin Name	Pin No.	I/O	Description	Comment
USB_VBUS	8	AI	USB connection detect	Typical 5.0 V
USB_DP	9	AIO	USB differential data (+)	Require differential impedance of 90 Ω .
USB_DM	10	AIO	USB differential data (-)	

¹³ It is not recommended to use USB for data communication, as the use of USB will increase the power consumption.

GND 3 Ground

For more details about USB 2.0 specification, visit <http://www.usb.org/home>.

The USB interface is recommended to be reserved for firmware upgrade and software debugging in application designs. The following figure shows a reference design of USB interface.

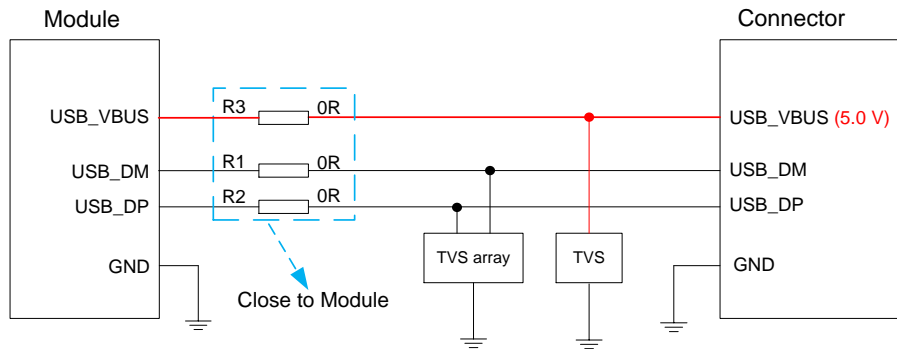

Figure 24: Reference Design of USB Interface

To ensure the integrity of USB data trace signal, resistors should be placed close to the module, and also these resistors should be placed close to each other. The extra stubs of trace must be as short as possible.

To meet USB 2.0 specification, comply with the following principles while designing the USB interface.

- It is important to route the USB signal traces as differential pairs with ground surrounded. The impedance of USB differential trace is 90 Ω.
- Do not route signal traces under crystals, oscillators, magnetic devices and RF signal traces. It is important to route the USB differential traces in inner-layer of the PCB, and surround the traces with ground on that layer and with ground planes above and below.
- Junction capacitance of the ESD protection components might cause influences on USB data traces, so pay attention to the selection of the components. Typically, the junction capacitance should be less than 2 pF.
- Keep the TVS components as close to the USB connector as possible.

NOTE

The USB interface supports slave mode only.

3.13. UART

The module provides four UART: the main UART, UART1, UART2 and UART3.

- The main UART is designed for AT command communication and data communication. It supports 9600, 19200, 38400, 57600, 115200, 230400, 460800, 921600, 2000000, 2900000, 3000000, 3200000, 3686400 and 4000000 bps baud rates. The default baud rate is 115200 bps.
- UART1, UART2 and UART3 are used for communication with peripherals, and they are multiplexed from GPIOs.

Table 16: Pin Definition of Main UART

Pin Name	Pin No.	I/O	Description	Comment
MAIN_DTR	30	DI	Main UART data terminal ready	
MAIN_RXD	34	DI	Main UART receive	1.8 V power domain.
MAIN_TXD	35	DO	Main UART transmit	
MAIN_CTS	36	DO	Clear to send signal from the module	Connect to the MCU's CTS. 1.8 V power domain. If unused, keep the pin open.
MAIN_RTS	37	DI	Request to send signal to the module	Connect to the MCU's RTS. 1.8 V power domain. If unused, keep the pin open.
MAIN_DCD	38	DO	Main UART data carrier detect	1.8 V power domain.
MAIN_RI	39	DO	Main UART ring indication	

NOTE

1. `qapi_UART_loctl()` can be used to set the baud rate of the main UART. See **document [5]** for more details about the API.
2. `qapi_QT_Main_UART_Enable_Set()` can be used to configure the main UART as a general-purpose UART in QuecOpen applications. See **document [4]** for more details about the API.

Table 17: Pin Definition of UART1

Pin Name	Pin No.	I/O	Function 1	Function 2	Function 3	Function 4	Comment
GPIO7	22	DIO	GPIO_1	UART1_RXD	-	-	1.8 V power domain.
GPIO8	23	DIO	GPIO_0	UART1_TXD	-	-	

Table 18: Pin Definition of UART2

Pin Name	Pin No.	I/O	Function 1	Function 2	Function 3	Function 4	Comment
GPIO15	64	DIO	GPIO_12	UART2_TXD	SPI2_MOSI	-	1.8 V power domain.
GPIO16	65	DIO	GPIO_13	UART2_RXD	SPI2_MISO	-	

NOTE

BG95-MF does not support GPIO15 and GPIO16 interfaces (pin 64 and pin 65).

Table 19: Pin Definition of UART3

Pin Name	Pin No.	I/O	Function 1	Function 2	Function 3	Function 4	Comment
GPIO11	27	DIO	GPIO_4	UART3_TXD	SPI1_MOSI	-	BOOT_CONFIG Do not pull it up before startup. 1.8 V power domain
GPIO12	28	DIO	GPIO_5	UART3_RXD	SPI1_MISO	-	1.8 V power domain

NOTE

1. The pin functions 1/2/3/4 take effect only after software configuration.
2. GPIO11 (pin 27) is a BOOT_CONFIG pin. Never pull them up before startup, otherwise the module cannot turn on normally.

The module provides 1.8 V UART. A voltage-level translator should be used if your application is equipped with a 3.3 V UART. The voltage-level translator TXS0108EPWR provided by Texas Instruments is recommended.

The following figure shows a reference design of the main UART.

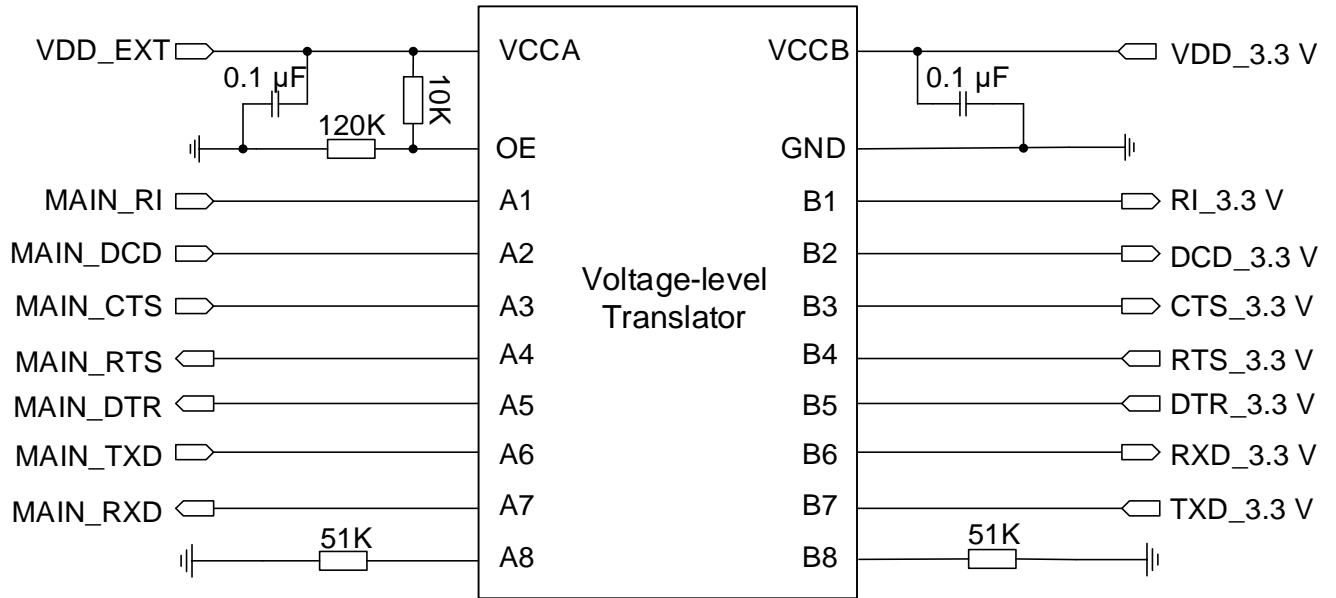

Figure 25: A Reference Design of the Main UART (IC Solution)

Visit <http://www.ti.com/> for more information.

Another example with transistor circuit is shown as below. For the design of circuits in dotted lines, refer to that of circuits in solid lines, but pay attention to the direction of connection.

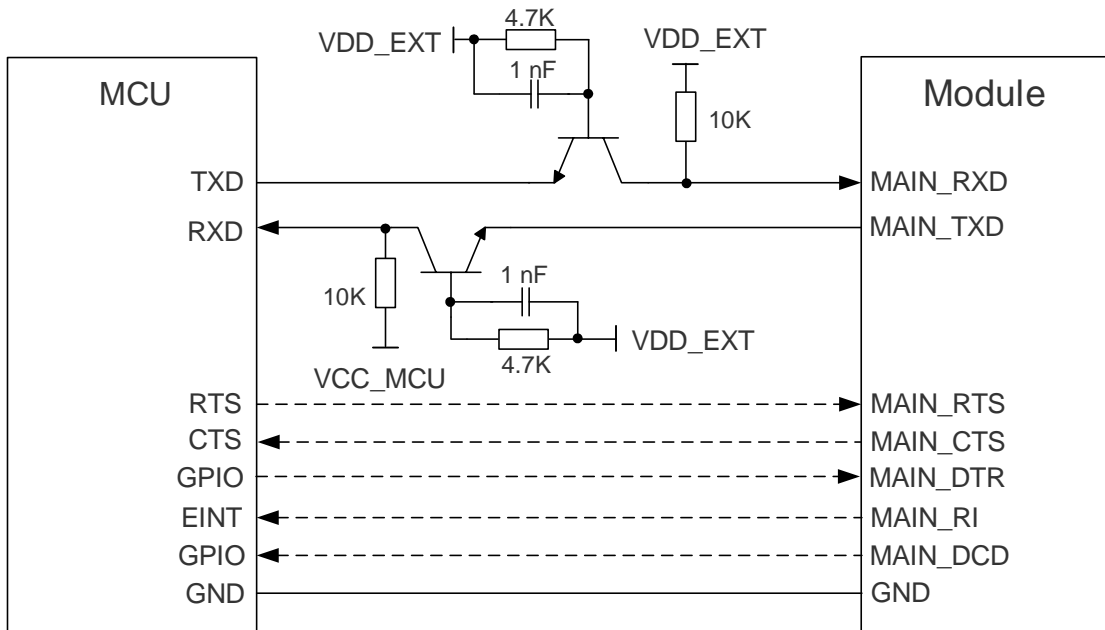

Figure 26: A Reference Design of the Main UART (Transistor Solution)

NOTE

1. Transistor solution is not suitable for applications with high baud rates exceeding 460 kbps.
2. Please note that the module's CTS is connected to the MCU's CTS, and the module's RTS is connected to the MCU's RTS.
3. The level shifting of UART2 and UART3 is similar to UART1.

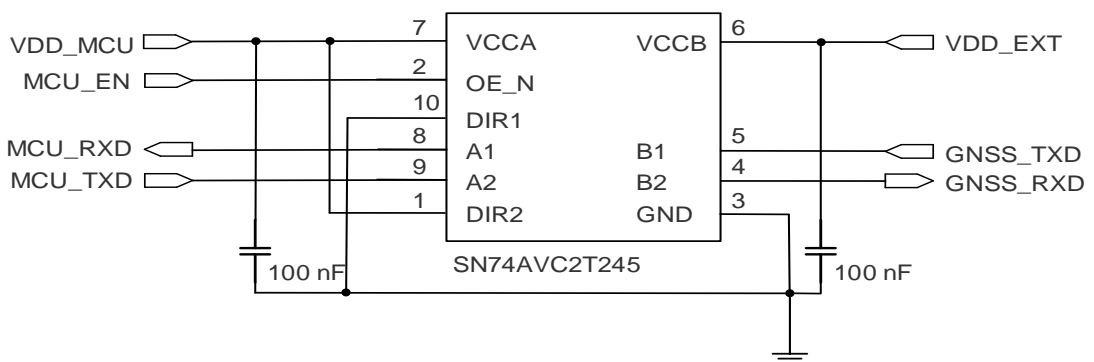

Figure 27: A Reference Design of UART3 (IC Solution Without Internal Pull-up)

NOTE

UART3 contains a BOOT_CONFIG pin (pin 27), therefore the IC solution with pull-up circuit or transistor /MOSFET solution is not applicable. It is recommended to adopt an IC solution without internal pull-up.

3.14. I2C Interface

The module provides one Inter-Integrated Circuit (I2C) interface for data communication. The interface supports fast-mode plus and master mode.

The pins of I2C interface are open drain and are multiplexed from GPIOs and are open drain that should be pulled up to 1.8 V. The pull-up resistors should be provided externally.

Table 20: Pin Definition of the I2C Interface

Pin Name	Pin No.	I/O	Function 1	Function 2	Function 3	Function 4	Comment
GPIO5	18	DIO	GPIO_3	-	-	I2C1_SCL	1.8 V power domain.
GPIO6	19	DIO	GPIO_2	-	-	I2C1_SDA	

NOTE

The pin functions 1/2/3/4 take effect only after software configuration.

The following figure shows a reference design of I2C interface with an external I2C interface sensor.

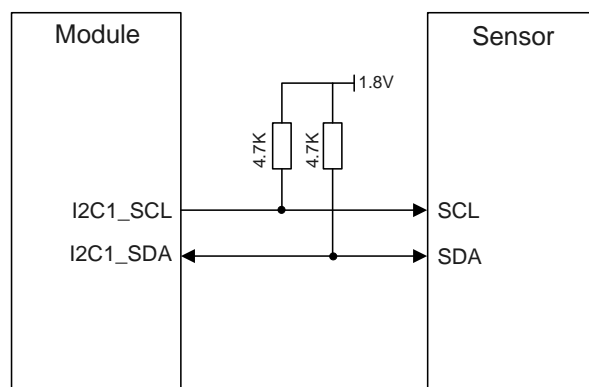

Figure 28: A Reference Design of I2C Interface with an External I2C Interface Sensor

3.15. SPI Interfaces

The module provides two SPI interfaces. SPI1 and SPI2 interfaces support master mode only, up to 50 MHz.

Table 21: Pin Definition of the SPI1 Interface

Pin Name	Pin No.	I/O	Function 1	Function 2	Function 3	Function 4	Comment
GPIO9	25	DIO	GPIO_6	-	SPI1_CS_N	-	1.8 V power domain.
GPIO10	26	DIO	GPIO_7	-	SPI1_CLK	-	1.8 V power domain.
GPIO11	27	DIO	GPIO_4	UART3_TXD	SPI1_MOSI	-	BOOT_CONFIG Do not pull it up before startup. 1.8 V power domain.
GPIO12	28	DIO	GPIO_5	UART3_RXD	SPI1_MISO	-	1.8 V power domain.

Table 22: Pin Definition of the SPI2 Interface

Pin Name	Pin No.	I/O	Function 1	Function 2	Function 3	Function 4	Comment
GPIO13	40	DIO	GPIO_15	-	SPI2_CLK	-	1.8 V power domain.
GPIO14	41	DIO	GPIO_14	-	SPI2_CS_N	-	1.8 V power domain.
GPIO15	64	DIO	GPIO_12	UART2_TXD	SPI2_MOSI	-	1.8 V power domain.
GPIO16	65	DIO	GPIO_13	UART2_RXD	SPI2_MISO	-	1.8 V power domain.

NOTE

1. The pin functions 1/2/3/4 take effect only after software configuration.
2. BG95-MF does not support GPIO15 and GPIO16 interfaces (pin 64 and pin 65).

The SPI timing at 50 MHz and other related parameters are shown as below.

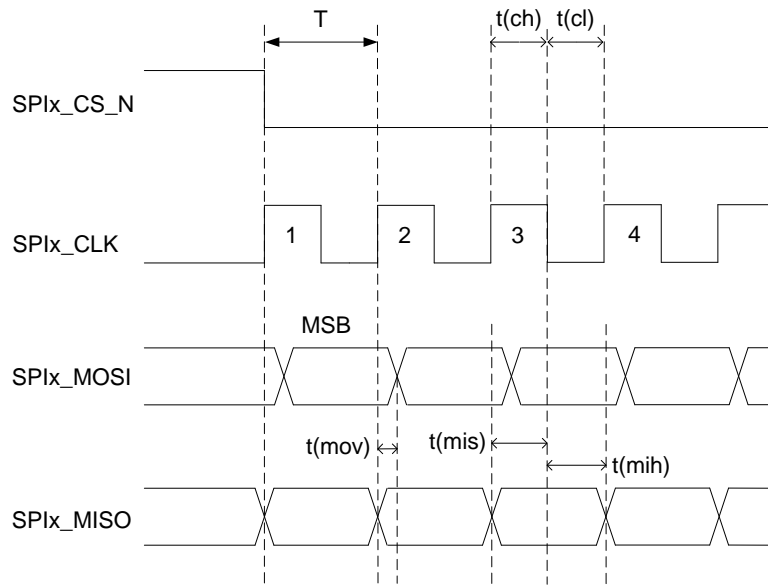

Figure 29: SPI Timing (Master Mode)

Table 23: Parameters of SPI Timing at 50 MHz

Parameter	Description	Min.	Typ.	Max.	Unit
T	SPI clock period: 50 MHz	20.0	-	-	ns
t(ch)	Clock high	9.0	-	-	ns
t(cl)	Clock low	9.0	-	-	ns
t(mov)	Master output valid	-5.0	-	5.0	ns
t(mis)	Master input setup	5.0	-	-	ns
t(mih)	Master input hold	1.0	-	-	ns

NOTE

The power domain of the SPI interface is 1.8 V. A voltage-level translator should be used between the module and the host if your application is equipped with a 3.3 V processor or device interface.

3.16. ADC Interfaces

The module provides two analog-to-digital converter (ADC) interfaces but only one ADC interface can be used at a time since ADC1 connects directly to ADC0 inside the module.

`qapi_ADC_Read_Channel()` can be used to read the voltage value on the ADC being used. For more details about the API, see **document [5]**.

To improve the accuracy of ADC voltage values, the traces of ADC should be surrounded with ground.

Table 24: Pin Definition of ADC Interfaces

Pin Name	Pin No.	I/O	Description	Comment
ADC0	24	AI	General-purpose ADC interface	Do not use ADC0 and ADC1 simultaneously.
ADC1	2	AI	General-purpose ADC interface	

Table 25: Characteristics of ADC Interfaces

Parameter	Min.	Typ.	Max.	Unit
Voltage Range	0.1	-	1.8	V
Resolution (LSB)	-	64.897	-	μV
Analog Bandwidth	-	500	-	kHz
Sample Clock	-	4.8	-	MHz
Input Resistance	10	-	-	MΩ

NOTE

1. It is prohibited to supply any voltage to ADC pins when VBAT is removed.
2. It is recommended to use resistor divider circuit for ADC application, and the divider resistor accuracy should be not less than 1 %.
3. Do not use ADC0 and ADC1 simultaneously, as ADC1 connects directly to ADC0 inside the module.

3.17. MAIN_RI

AT+QCFG="risignalttype","physical" can be used to configure MAIN_RI behavior. No matter which port a URC is presented on, the URC will trigger the behavior of MAIN_RI.

Table 26: Default Behaviours of MAIN_RI

State	Response
Idle	MAIN_RI keeps at a high level.
URC	MAIN_RI outputs 120 ms low pulse when a new URC returns.

The default MAIN_RI behaviors can be configured flexibly by **AT+QCFG="urc/ri/ring"**. For more details about **AT+QCFG**, see *document [6]*.

NOTE

A URC can be output from the main UART through configuration via *qapi_QT_URC_Port_Set()*. See *document [4]* for details about the API function.

3.18. Network Status Indication

The module provides one network status indication pin: NET_STATUS. The pin is used to drive a network status indication LED. The following tables describe the pin definition and logic level changes of NET_STATUS in different network activity status.

Table 27: Pin Definition of NET_STATUS

Pin Name	Pin No.	I/O	Description	Comment
NET_STATUS	21	DO	Indicate the module's network activity status	1.8 V power domain. If unused, keep this pin open.

Table 28: Operating Status of NET_STATUS

Pin Name	Indicator Status (Logic Level Changes)	Network Status
NET_STATUS	Flicker slowly (200 ms High/1800 ms Low)	Network searching
	Flicker slowly (1800 ms High/200 ms Low)	Idle
	Flicker quickly (125 ms High/125 ms Low)	Data transfer is ongoing

A reference design is shown in the following figure.

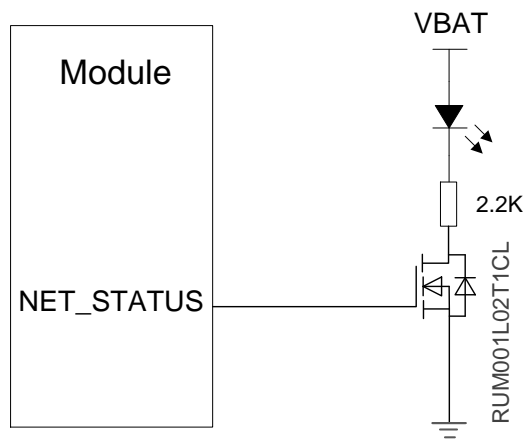

Figure 30: A Reference Design of NET_STATUS

3.19. STATUS

The STATUS pin is used to indicate the operation status of the module. It outputs high level when the module turns on.

Table 29: Pin Definition of STATUS

Pin Name	Pin No.	I/O	Description	Comment
STATUS	20	DO	Indicate the module's operation status	1.8 V power domain. If unused, keep this pin open.

The following figure shows a reference design of STATUS.

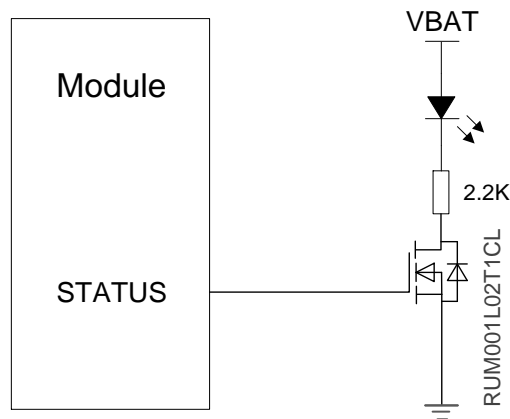

Figure 31: A Reference Design of STATUS

3.20. USB_BOOT

The module provides a USB_BOOT pin. During development or factory production, USB_BOOT can force the module to boot from USB interface for firmware upgrade.

Table 30: Pin Definition of USB_BOOT Interface

Pin Name	Pin No.	I/O	Description	Comment
USB_BOOT	75	DI	Force the module into emergency download mode.	1.8 V power domain. Active high. If unused, keep it open.

The following figure shows a reference design of USB_BOOT interface.

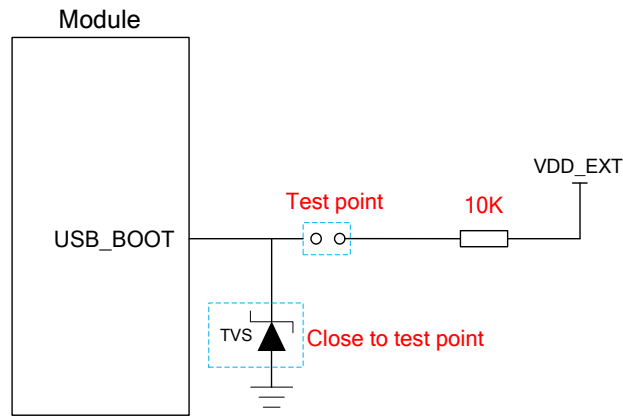

Figure 32: A Reference Design of USB_BOOT Interface

The following figure shows the timing of USB_BOOT.

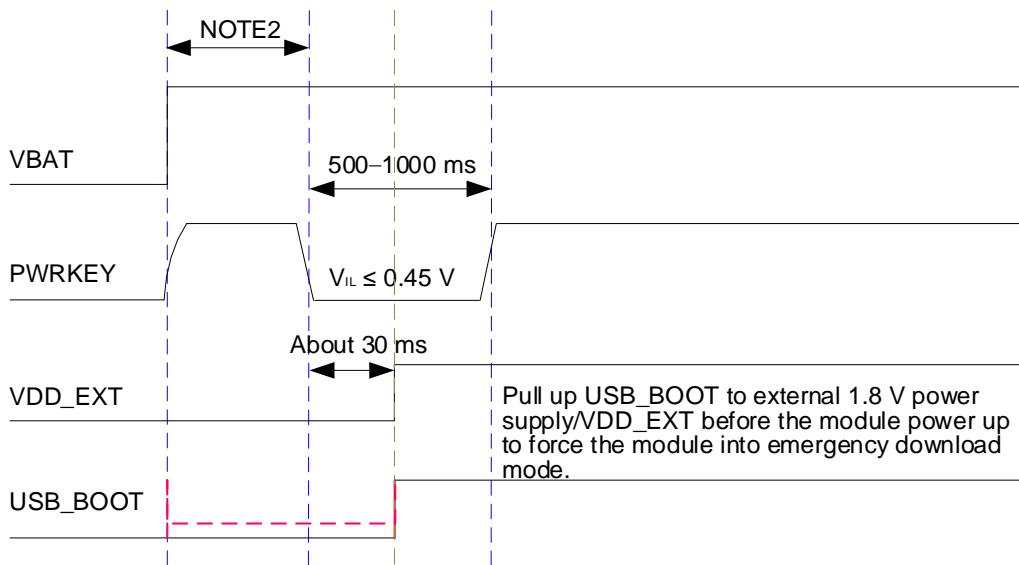

Figure 33: Timing for Turning on the Module with USB_BOOT

NOTE

1. It is recommended to reserve the above circuit design during application design.
2. Make sure that VBAT is stable before pulling down PWRKEY. It is recommended that the time difference between powering up VBAT and pulling down PWRKEY is not less than 30 ms.
3. When using MCU to control if the module enters emergency download mode, follow the above timing. Connecting the test points as shown in **Figure 32** can manually force the module into download mode.

3.21. GRFC Interfaces

The module provides two generic RF control interfaces for the control of external antenna tuners.

Table 31: Pin Definition of GRFC Interfaces

Pin Name	Pin No.	I/O	Description	Comment
GRFC1	83	DO	Generic RF controller	1.8V power domain. If unused, keep this pin open.
GRFC2	84			BOOT_CONFIG. Do not pull it up before startup. 1.8 V power domain.

Table 32: Truth Table of GRFC Interfaces

GRFC1 Level	GRFC2 Level	Frequency Range (MHz)	Band
Low	Low	880–2180	B1, B2, B3, B4, B8, B25, B66
Low	High	791–894	B5, B18, B19, B20, B26, B27
High	Low	698–803	B12, B13, B28, B85
High	High	617–698	B71

NOTE

1. GRFC2 (pin 84) is a BOOT_CONFIG pin. Never pull it up before startup, otherwise the module cannot turn on normally.
2. BG95-M4, BG95-M8 and BG95-M9 do not support GRFC interfaces.

4 GNSS

4.1. General Description

The module includes a fully integrated global navigation satellite system solution that supports GPS, GLONASS, BDS, Galileo and QZSS.

The module supports standard NMEA 0183 protocol, and outputs NMEA sentences at 1 Hz data update rate via USB interface by default.

By default, the GNSS engine is switched off. It has to be switched on via AT command. The module does not support concurrent operation of WWAN and GNSS. For more details about GNSS engine technology and configurations, see *document [1]*.

4.2. GNSS Performance

Table 33: GNSS Performance

Parameter	Description	Conditions	Typ.	Unit
Sensitivity	Acquisition	Autonomous	-146	dBm
	Reacquisition	Autonomous	-157	dBm
	Tracking	Autonomous	-157	dBm
TTFF	Cold start @ open sky	Autonomous	31.01	s
		XTRA enabled	10.4	s
	Warm start @ open sky	Autonomous	30.58	s
		XTRA enabled	1.53	s
	Hot start	Autonomous	1.6	s

	@ open sky	XTRA enabled	1.5	s
Accuracy	CEP-50	Autonomous @ open sky	2.5	m

NOTE

1. Tracking sensitivity: the minimum GNSS signal power at which the module can maintain lock (keep positioning for at least 3 minutes continuously).
2. Reacquisition sensitivity: the minimum GNSS signal power required for the module to maintain lock within 3 minutes after loss of lock.
3. Acquisition sensitivity: the minimum GNSS signal power at which the module can fix position successfully within 3 minutes after executing cold start command.

4.3. Layout Guidelines

The following layout guidelines should be taken into account in application designs.

- Maximize the distance between the GNSS antenna and the main antenna.
- Digital circuits such as (U)SIM card, USB interface, camera module, display connector and SD card should be kept away from the antennas.
- Use ground vias around the GNSS trace and sensitive analog signal traces to provide coplanar isolation and protection.
- Keep 50 Ω characteristic impedance for ANT_GNSS trace.

See **Chapter 5** for GNSS antenna reference design and antenna installation information.

5 Antenna Interfaces

The module includes a main antenna interface and a GNSS antenna interface. Additionally, BG95-MF supports Wi-Fi antenna interface. The impedance of antenna ports is 50 Ω.

5.1. Main Antenna Interface

5.1.1. Pin Definition

Table 34: Pin Definition of the Main Antenna Interface

Pin Name	Pin No.	I/O	Description	Comment
ANT_MAIN	60	AIO	Main antenna interface	50 Ω impedance

5.1.2. Operating Frequency

Table 35: Operating Frequency

3GPP Band	Transmit	Receive	Unit
GSM850	824–849	869–894	MHz
EGSM900	880–915	925–960	MHz
DCS1800	1710–1785	1805–1880	MHz
PCS1900	1850–1910	1930–1990	MHz
LTE HD-FDD B1	1920–1980	2110–2170	MHz
LTE HD-FDD B2	1850–1910	1930–1990	MHz
LTE HD-FDD B3	1710–1785	1805–1880	MHz

LTE HD-FDD B4	1710–1755	2110–2155	MHz
LTE HD-FDD B5	824–849	869–894	MHz
LTE HD-FDD B8	880–915	925–960	MHz
LTE HD-FDD B12	699–716	729–746	MHz
LTE HD-FDD B13	777–787	746–756	MHz
LTE HD-FDD B18	815–830	860–875	MHz
LTE HD-FDD B19	830–845	875–890	MHz
LTE HD-FDD B20	832–862	791–821	MHz
LTE HD-FDD B25	1850–1915	1930–1995	MHz
LTE HD-FDD B26	814–849	859–894	MHz
LTE HD-FDD B27	807–824	852–869	MHz
LTE HD-FDD B28	703–748	758–803	MHz
LTE HD-FDD B31	452.5–457.5	462.5–467.5	MHz
LTE HD-FDD B66	1710–1780	2110–2180	MHz
LTE HD-FDD B71	663–698	617–652	MHz
LTE HD-FDD B72	451–456	461–466	MHz
LTE HD-FDD B73	450–455	460–465	MHz
LTE HD-FDD B85	698–716	728–746	MHz
LTE HD-FDD B86	787–788	757–758	MHz
LTE HD-FDD B87	410–415	420–425	MHz
LTE HD-FDD B88	412–417	422–427	MHz

NOTE

1. LTE HD-FDD B26 and B27 are supported by Cat M1 only.
2. LTE HD-FDD B31, B72 and B73 are supported by BG95-M4, BG95-M8 and BG95-M9.
3. LTE HD-FDD B71 is supported by Cat NB2 only.

5.1.3. Reference Design

A reference design of the main antenna interface is shown as below. It is recommended to reserve a π -type matching circuit for better RF performance, and the π -type matching components (R1/C1/C2) should be placed as close to the antenna as possible. The capacitors are not mounted by default.

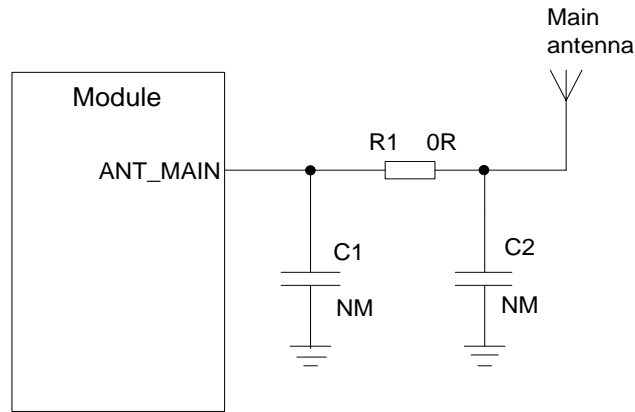

Figure 34: A Reference Design of the Main Antenna Interface

5.2. GNSS Antenna Interface

5.2.1. Pin Definition

Table 36: Pin Definition of GNSS Antenna Interface

Pin Name	Pin No.	I/O	Description	Comment
ANT_GNSS	49	AI	GNSS antenna interface	50 Ω impedance. If unused, keep this pin open.

5.2.2. GNSS Operating Frequency

Table 37: GNSS Operating Frequency

Type	Frequency	Unit
GPS	1575.42 ±1.023	MHz
GLONASS	1597.5–1605.8	MHz
Galileo	1575.42 ±2.046	MHz
BDS	1561.098 ±2.046	MHz
QZSS	1575.42 ±1.023	MHz

5.2.3. Reference Design

A reference design of GNSS antenna interface is shown as below.

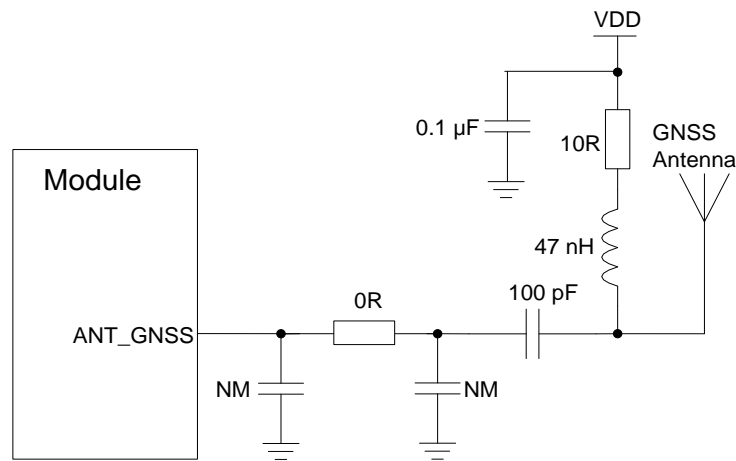

Figure 35: A Reference Design of GNSS Antenna Interface

NOTE

1. An external LDO can be selected to supply power according to the active antenna requirement.
2. If the module is designed with a passive antenna, then the VDD circuit is not needed.

5.3. Wi-Fi Antenna Interface

BG95-MF supports Wi-Fi antenna interface through which the module performs Wi-Fi scan (receiving only).

5.3.1. Pin Definition

Table 38: Pin Definition of Wi-Fi Antenna Interface

Pin Name	Pin No.	I/O	Description	Comment
ANT_WIFI	56	AI	Wi-Fi antenna interface	50 Ω impedance.

5.3.2. Wi-Fi Operating Frequency

Table 39: Wi-Fi Operating Frequency

Standard	Frequency	Unit
802.11b/g/n	2400–2483.5	MHz

5.3.3. Reference Design

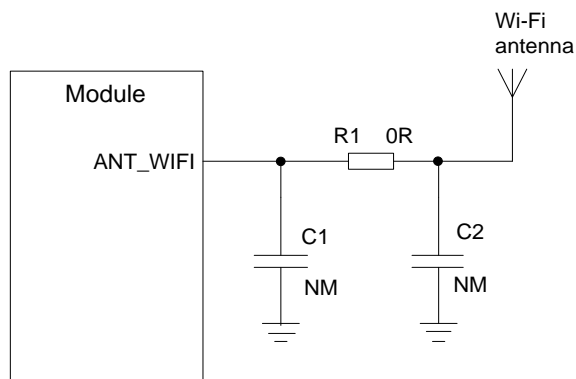

Figure 36: A Reference Design of Wi-Fi Antenna Interface

5.4. RF Routing Guidelines

For your PCB, the characteristic impedance of all RF traces should be controlled to 50 Ω. The impedance of the RF traces is usually determined by the trace width (W), the materials' dielectric constant, the height from the reference ground to the signal layer (H), and the spacing between RF traces and grounds (S). Microstrip or coplanar waveguide is typically used in RF layout to control characteristic impedance. The following are reference designs of microstrip or coplanar waveguide with different PCB structures.

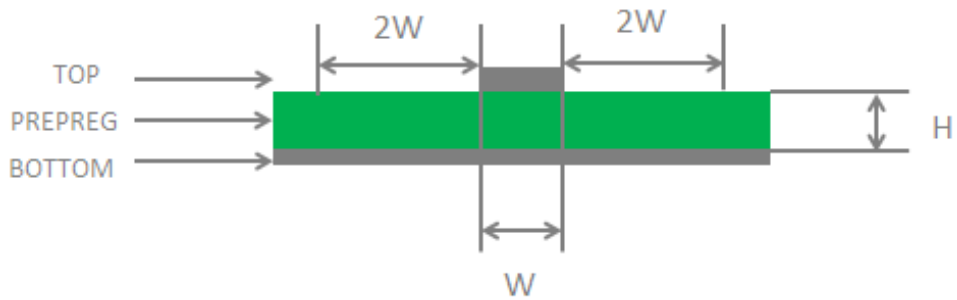

Figure 37: Microstrip Design on a 2-layer PCB

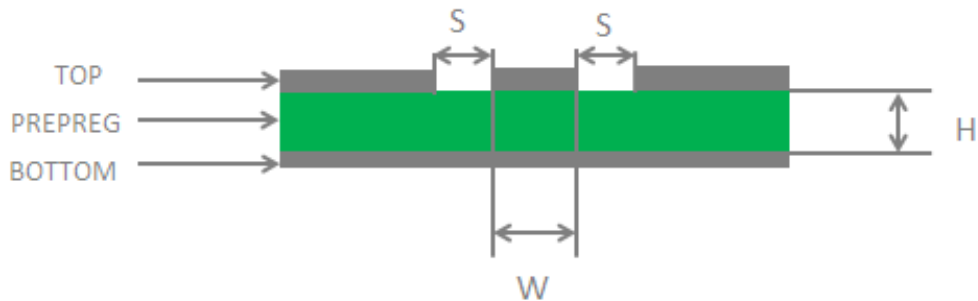

Figure 38: Coplanar Waveguide Design on a 2-layer PCB

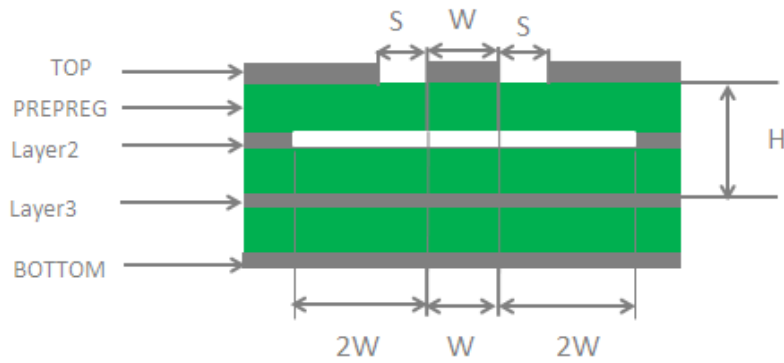

Figure 39: Coplanar Waveguide Design on a 4-layer PCB (Layer 3 as Reference Ground)

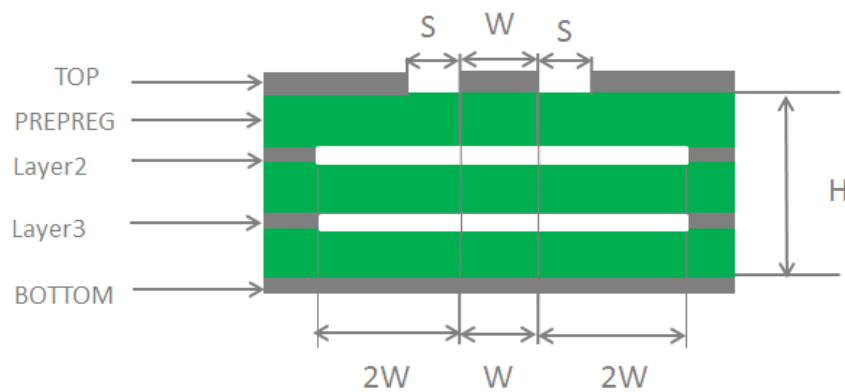

Figure 40: Coplanar Waveguide Design on a 4-layer PCB (Layer 4 as Reference Ground)

To ensure RF performance and reliability, the following principles should be complied with in RF layout design:

- Use an impedance simulation tool to accurately control the characteristic impedance of RF traces to 50 Ω.
- The GND pins adjacent to RF pins should not be designed as thermal relief pads, and should be fully connected to ground.
- The distance between the RF pins and the RF connector should be as short as possible, and all the right-angle traces should be changed to curved ones. The recommended trace angle is 135°.
- There should be clearance under the signal pin of the antenna connector or solder joint.
- The reference ground of RF traces should be complete. Meanwhile, adding some ground vias around RF traces and the reference ground could help to improve RF performance. The distance between the ground vias and RF traces should be not less than twice as wide as the RF signal traces ($2 \times W$).
- Keep RF traces away from interference sources, and avoid intersection and paralleling between traces on adjacent layers.

For more details about RF layout, see **document [7]**.

5.5. Antenna Installation

5.5.1. Antenna Design Requirements

Table 40: Antenna Requirements

Antenna Type	Requirements
GNSS ¹⁴	Frequency range: 1559–1609 MHz Polarization: RHCP or linear VSWR: ≤ 2 (Typ.) Passive antenna gain: > 0 dBi Active antenna noise figure: < 1.5 dB Active antenna gain: > 0 dBi Active antenna embedded LNA gain: < 17 dB
LTE/GSM	VSWR: ≤ 2 Efficiency: > 30 % Max Input Power: 50 W Input Impedance: 50 Ω Cable Insertion Loss: < 1 dB: LB (<1 GHz) < 1.5 dB: MB (1–2.3 GHz)
Wi-Fi (For BG95-MF only)	VSWR: ≤ 2 Gain: 1 dBi Max Input Power: 50 W Input Impedance: 50 Ω Polarization Type: Vertical Cable Insertion Loss: < 1 dB

¹⁴ It is recommended to use a passive GNSS antenna when LTE HD-FDD B13 is supported, as the use of active antenna may generate harmonics which will affect the GNSS performance.

5.5.2. RF Connector Recommendation

If RF connector is used for antenna connection, it is recommended to use U.FL-R-SMT connectors provided by Hirose.

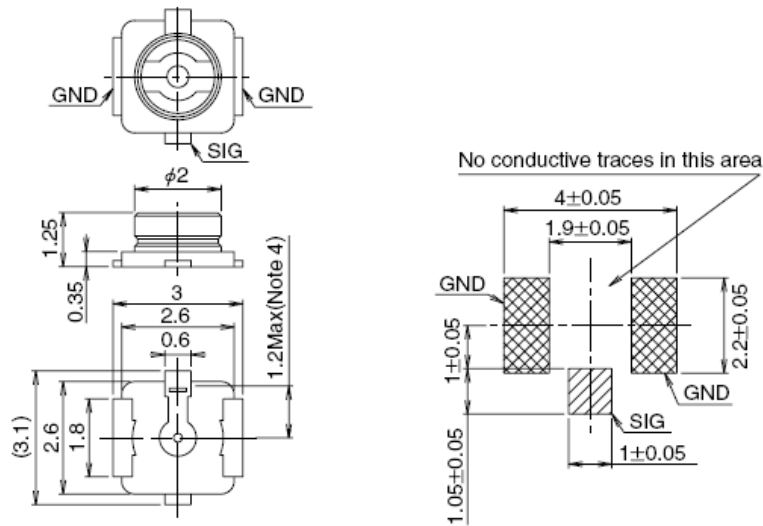

Figure 41: Dimensions of the Receptacle (Unit: mm)

U.FL-LP series mated plugs listed in the following figure can be used to match the U.FL-R-SMT.

	U.FL-LP-040	U.FL-LP-066	U.FL-LP(V)-040	U.FL-LP-062	U.FL-LP-088
Part No.					
Mated Height	2.5mm Max. (2.4mm Nom.)	2.5mm Max. (2.4mm Nom.)	2.0mm Max. (1.9mm Nom.)	2.4mm Max. (2.3mm Nom.)	2.4mm Max. (2.3mm Nom.)
Applicable cable	Dia. 0.81mm Coaxial cable	Dia. 1.13mm and Dia. 1.32mm Coaxial cable	Dia. 0.81mm Coaxial cable	Dia. 1mm Coaxial cable	Dia. 1.37mm Coaxial cable
Weight (mg)	53.7	59.1	34.8	45.5	71.7
RoHS	YES				

Figure 42: Specifications of Mated Plugs

The following figure describes the space factor of mated connectors.

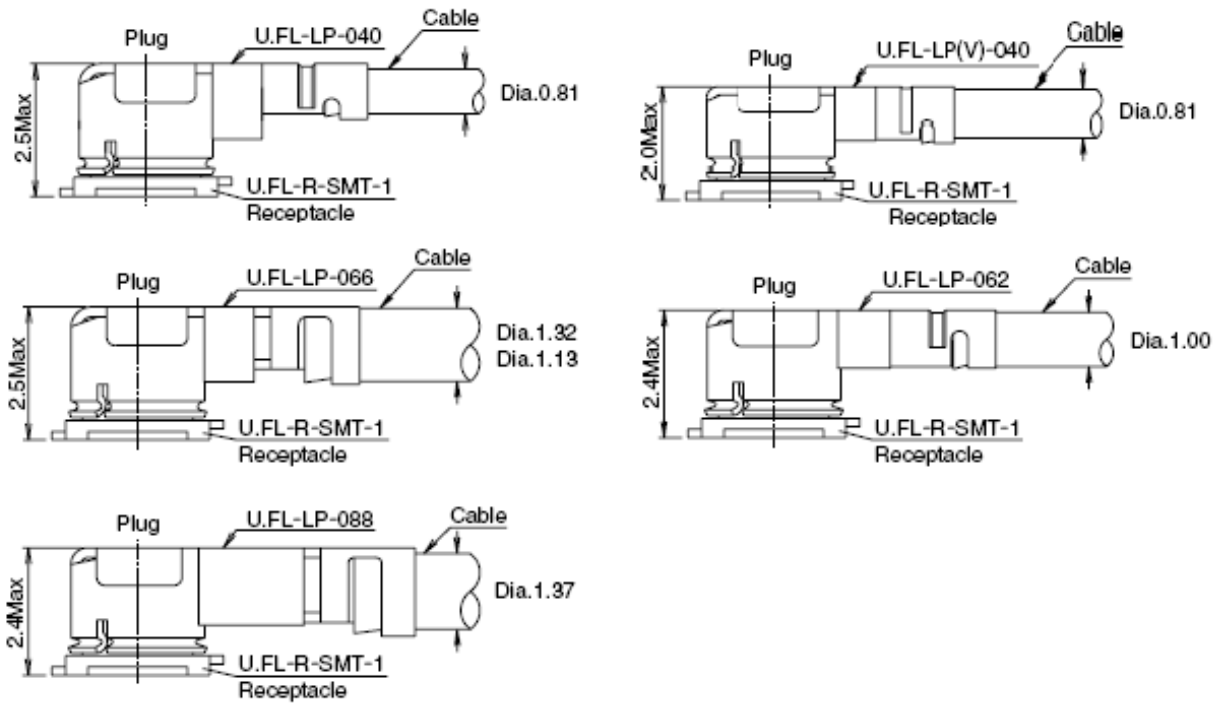

Figure 43: Space Factor of Mated Connectors (Unit: mm)

For more details, visit <http://www.hirose.com>.

6 Electrical Characteristics and Reliability

6.1. Absolute Maximum Ratings

Absolute maximum ratings for power supply and voltage on digital pins of the module are listed in the following table.

Table 41: Absolute Maximum Ratings

Parameter	Min.	Max.	Unit
VBAT_BB	-0.5	6.0	V
VBAT_RF	-0.3	6.0	V
USB_VBUS	-0.3	5.5	V
Voltage at Digital Pins	-0.3	2.09	V

6.2. Power Supply Ratings

Table 42: Power Supply Ratings

Parameter	Description	Conditions	Module	Min.	Typ.	Max.	Unit
VBAT	VBAT_BB/ VBAT_RF	The actual input voltages must be kept between the	BG95-M1/ BG95-M2	2.6 ¹⁵	3.3	4.8	V
			BG95-M3/	3.3	3.8	4.3	V

¹⁵ For every VBAT transition/re-insertion from 0 V, the minimum power supply voltage should be higher than 2.7 V. After the module starts up normally, the minimum safety voltage is 2.6 V. To ensure full-function mode, the minimum power supply voltage should be higher than 2.8 V.

		minimum and the maximum values.	BG95-M5/ BG95-M6/ BG95-MF/ BG95-M8					
			BG95-M4/ BG95-M9	3.2	3.8	4.2	V	
I _{VBAT}	Peak power consumption (during transmission slot)	At maximum power control level	BG95-M3/ BG95-M5/ BG95-M8	-	1.8	2.7	A	
	Peak power consumption	In LTE Cat M1 and/or Cat NB2 transmission modes.	BG95-M1/ BG95-M2/ BG95-M4/ BG95-M6/ BG95-MF/ BG95-M9	-	0.8	1.0	A	
USB_VBUS	USB connection detection		BG95 series	4.0	5.0	5.25	V	

6.3. Operating and Storage Temperatures

Table 43: Operating and Storage Temperatures

Parameter	Min.	Typ.	Max.	Unit
Operating Temperature Range ¹⁶	-35	+25	+75	°C
Extended Temperature Range ¹⁷	-40	-	+85	°C
Storage Temperature Range	-40	-	+90	°C

¹⁶ Within the operating temperature range, the module meets 3GPP specifications.

¹⁷ Within the extended temperature range, the module remains the ability to establish and maintain functions such as SMS and data transmission, without any unrecoverable malfunction. Radio spectrum and radio network are not influenced, while one or more specifications, such as P_{out}, may exceed the specified tolerances of 3GPP. When the temperature returns to the operating temperature range, the module meets 3GPP specifications again.

6.4. Power Consumption

Table 44: BG95-M1 Power Consumption (3.3 V Power Supply, Room Temperature)

Description	Conditions	Average	Unit
Leakage ¹⁸	Power-off @ USB and UART disconnected	14	μA
PSM ¹⁹	Power Saving Mode	4	μA
Rock Bottom	AT+CFUN=0 @ Sleep mode	0.53	mA
Sleep Mode (USB disconnected)	LTE Cat M1 DRX = 1.28 s	1.7	mA
	LTE Cat M1 e-I-DRX = 81.92 s @ PTW = 2.56 s, DRX = 1.28 s	0.577	mA
Idle Mode (USB disconnected)	LTE Cat M1 DRX = 1.28 s	20	mA
	LTE Cat M1 e-I-DRX = 81.92 s @ PTW = 2.56 s, DRX = 1.28 s	19.57	mA
LTE Cat M1 data transfer (GNSS OFF)	B1 @ 20.66 dBm	200.47	mA
	B2 @ 20.81 dBm	202.12	mA
	B3 @ 21.24 dBm	199.57	mA
	B4 @ 20.82 dBm	197.79	mA
	B5 @ 21.12 dBm	219.9	mA
	B8 @ 21.03 dBm	209.96	mA
	B12 @ 20.67 dBm	202.55	mA
	B13 @ 20.92 dBm	225.42	mA
	B18 @ 21.02 dBm	214.87	mA
B19 @ 20.95 dBm	216.17	mA	

¹⁸ The power consumption of the module in PSM is much lower than that in turn-off mode, due to the following two designs:

- More internal power supplies are turned off in PSM.
- The internal clock frequency is also reduced in PSM.

¹⁹ The module's USB and UART are disconnected, and GSM network (if available) does not support PSM.

B20 @ 20.96 dBm	214.52	mA
B25 @ 21.02 dBm	203.86	mA
B26 @ 21.06 dBm	218.97	mA
B27 @ 20.8 dBm	212.89	mA
B28A @ 20.89 dBm	210.15	mA
B28B @ 21 dBm	217.13	mA
B66 @ 21.03 dBm	198.63	mA
B85 @ 21 dBm	203.36	mA

Table 45: BG95-M2 Power Consumption (3.3 V Power Supply, Room Temperature)

Description	Conditions	Average	Unit
Leakage ¹⁸	Power-off @ USB and UART disconnected	12.46	μA
PSM ¹⁹	Power Saving Mode	3.89	μA
Rock Bottom	AT+CFUN=0 @ Sleep mode	0.554	mA
Sleep Mode (USB disconnected)	LTE Cat M1 DRX = 1.28 s	1.68	mA
	LTE Cat NB1 DRX = 1.28 s	1.55	mA
	LTE Cat M1 e-I-DRX = 81.92 s @ PTW = 2.56 s, DRX = 1.28 s	0.549	mA
	LTE Cat NB1 e-I-DRX = 81.92 s @ PTW = 2.56 s, DRX = 1.28 s	0.592	mA
Idle Mode (USB disconnected)	LTE Cat M1 DRX = 1.28 s	21.2	mA
	LTE Cat NB1 DRX = 1.28 s	16.8	mA
	LTE Cat M1 e-I-DRX = 81.92 s @ PTW = 2.56 s, DRX = 1.28 s	20.6	mA
	LTE Cat NB1 e-I-DRX = 81.92 s @ PTW = 2.56 s, DRX = 1.28 s	16.4	mA

LTE Cat M1 data transfer (GNSS OFF)	B1 @ 20.96 dBm	200.76	mA
	B2 @ 21.16 dBm	204.65	mA
	B3 @ 21.19 dBm	198.23	mA
	B4 @ 21.36 dBm	199.07	mA
	B5 @ 20.97 dBm	218.17	mA
	B8 @ 20.72 dBm	208.15	mA
	B12 @ 21.08 dBm	211.45	mA
	B13 @ 21.01 dBm	223.86	mA
	B18 @ 21.03 dBm	220.07	mA
	B19 @ 21.03 dBm	217.55	mA
	B20 @ 21.03 dBm	220.29	mA
	B25 @ 20.87 dBm	204.23	mA
	B26 @ 21.02 dBm	217.94	mA
	B27 @ 21.2 dBm	222.32	mA
	B28A @ 20.71 dBm	210.33	mA
	B28B @ 20.6 dBm	216.98	mA
B66 @ 20.98 dBm	197.33	mA	
B85 @ 21.05 dBm	211.41	mA	
LTE Cat NB1 data transfer (GNSS OFF)	B1 @ 21.06 dBm	158.87	mA
	B2 @ 21.08 dBm	160.58	mA
	B3 @ 20.97 dBm	151.47	mA
	B4 @ 21.05 dBm	151.14	mA
	B5 @ 20.9 dBm	173.72	mA
	B8 @ 20.87 dBm	166.6	mA
B12 @ 21.05 dBm	161.94	mA	

B13 @ 20.88 dBm	180.98	mA
B18 @ 20.97 dBm	175.49	mA
B19 @ 20.99 dBm	174.59	mA
B20 @ 20.99 dBm	173.42	mA
B25 @ 20.96 dBm	157.75	mA
B28 @ 21 dBm	162.61	mA
B66 @ 21.19 dBm	152.1	mA
B71 @ 21.15 dBm	153.81	mA
B85 @ 21.32 dBm	166.88	mA

Table 46: BG95-M3 Power Consumption (3.8 V Power Supply, Room Temperature)

Description	Conditions	Average	Unit
Leakage ¹⁸	Power-off @ USB and UART disconnected	12.99	µA
PSM ¹⁹	Power Saving Mode	3.89	µA
Rock Bottom	AT+CFUN=0 @ Sleep mode	0.575	mA
Sleep Mode (USB disconnected)	LTE Cat M1 DRX = 1.28 s	1.89	mA
	LTE Cat NB1 DRX = 1.28 s	1.49	mA
	EGSM900 DRX = 5	1.21	mA
	DCS1800 DRX = 5	1.20	mA
	LTE Cat M1 e-I-DRX = 81.92 s @ PTW = 2.56 s, DRX = 1.28 s	0.63	mA
	LTE Cat NB1 e-I-DRX = 81.92 s @ PTW = 2.56 s, DRX = 1.28 s	0.67	mA
Idle Mode (USB disconnected)	LTE Cat M1 DRX = 1.28 s	18.9	mA
	LTE Cat NB1 DRX = 1.28 s	14.8	mA
	LTE Cat M1	18.2	mA

	e-I-DRX = 81.92 s @ PTW = 2.56 s, DRX = 1.28 s		
	LTE Cat NB1		
	e-I-DRX = 81.92 s @ PTW = 2.56 s, DRX = 1.28 s	14.3	mA
	B1 @ 21.29 dBm	193.65	mA
	B2 @ 20.73 dBm	190.76	mA
	B3 @ 20.67 dBm	185.89	mA
	B4 @ 20.85 dBm	185.14	mA
	B5 @ 21.02 dBm	194.99	mA
	B8 @ 21.02 dBm	197.31	mA
	B12 @ 20.96 dBm	189.54	mA
	B13 @ 20.99 dBm	198.75	mA
LTE Cat M1 data transfer (GNSS OFF)	B18 @ 21 dBm	195.07	mA
	B19 @ 20.95 dBm	197.63	mA
	B20 @ 20.92 dBm	197.33	mA
	B25 @ 21.08 dBm	190.67	mA
	B26 @ 20.98 dBm	195.96	mA
	B27 @ 20.69 dBm	192.07	mA
	B28A @ 20.87 dBm	192.04	mA
	B28B @ 21.03 dBm	197.39	mA
	B66 @ 21.11 dBm	188.1	mA
	B85 @ 20.87 dBm	185.3	mA
LTE Cat NB1 data transfer (GNSS OFF)	B1 @ 20.86 dBm	153.2	mA
	B2 @ 21.28 dBm	155.14	mA
	B3 @ 21.07 dBm	149.14	mA
	B4 @ 20.91 dBm	147.72	mA

	B5 @ 20.55 dBm	154.68	mA
	B8 @ 21.01 dBm	158.82	mA
	B12 @ 20.88 dBm	148.37	mA
	B13 @ 21.09 dBm	167.03	mA
	B18 @ 20.79 dBm	157.12	mA
	B19 @ 20.68 dBm	156.29	mA
	B20 @ 21.01 dBm	161.75	mA
	B25 @ 21.02 dBm	154.16	mA
	B28 @ 20.82 dBm	147.82	mA
	B66 @ 21 dBm	148.58	mA
	B71 @ 20.81 dBm	137.53	mA
	B85 @ 20.64 dBm	146.51	mA
GPRS data transfer (GNSS OFF)	GSM850 4UL/1DL @ 30.5 dBm	670.73	mA
	EGSM900 4UL/1DL @ 29.65 dBm	623.34	mA
	DCS1800 4UL/1DL @ 26.24 dBm	408.25	mA
	PCS1900 4UL/1DL @ 26.43 dBm	423.12	mA
	EGSM900 1UL/4DL @ 31.96 dBm	255.82	mA
	DCS1800 1UL/4DL @ 29.35 dBm	179.29	mA
EDGE data transfer (GNSS OFF)	GSM850 4UL/1DL @ 22.97 dBm	519	mA
	EGSM900 4UL/1DL @ 22.51 dBm	517.59	mA
	DCS1800 4UL/1DL @ 22.73 dBm	439.73	mA
	PCS1900 4UL/1DL @ 22.27 dBm	443.94	mA

Table 47: BG95-M4 Power Consumption (3.8 V Power Supply, Room Temperature)

Description	Conditions	Average	Unit
Leakage ¹⁸	Power-off @ USB and UART disconnected	13.76	μA
PSM ¹⁹	Power Saving Mode	3.94	μA
Rock Bottom	AT+CFUN=0 @ Sleep mode	0.556	mA
Sleep Mode (USB disconnected)	LTE Cat M1 DRX = 1.28 s	1.53	mA
	LTE Cat NB1 DRX = 1.28 s	1.39	mA
	LTE Cat M1 e-I-DRX = 81.92 s @ PTW = 2.56 s, DRX = 1.28 s	0.554	mA
	LTE Cat NB1 e-I-DRX = 81.92 s @ PTW = 2.56 s, DRX = 1.28 s	0.588	mA
	LTE Cat M1 DRX = 1.28 s	18.176	mA
	LTE Cat NB1 DRX = 1.28 s	14.425	mA
Idle Mode (USB disconnected)	LTE Cat M1 e-I-DRX = 81.92 s @ PTW = 2.56 s, DRX = 1.28 s	17.604	mA
	LTE Cat NB1 e-I-DRX = 81.92 s @ PTW = 2.56 s, DRX = 1.28 s	14.061	mA
	B1 @ 20.41 dBm	179.3	mA
	B2 @ 20.6 dBm	184.18	mA
LTE Cat M1 data transfer (GNSS OFF)	B3 @ 20.67 dBm	180.85	mA
	B4 @ 20.54 dBm	177.54	mA
	B5 @ 20.98 dBm	187.2	mA
	B8 @ 20.28 dBm	185.97	mA
	B12 @ 20.6 dBm	184.93	mA
	B13 @ 20.69 dBm	186.61	mA
	B18 @ 20.29 dBm	179.33	mA

	B19 @ 20.72 dBm	184.35	mA
	B20 @ 20.75 dBm	185.44	mA
	B25 @ 20.73 dBm	185.15	mA
	B26 @ 20.94 dBm	183.29	mA
	B27 @ 20.65 dBm	182.74	mA
	B28A @ 20.36 dBm	184.25	mA
	B28B @ 20.66 dBm	187.13	mA
	B31 @ 22.27 dBm	187.01	mA
	B31 @ 26.11 dBm	225.43	mA
	B66 @ 20.98 dBm	182.56	mA
	B72 @ 22.72 dBm	191.15	mA
	B72 @ 26.01 dBm	225.08	mA
	B73 @ 22.3 dBm	189.37	mA
	B73 @ 26.11 dBm	227.73	mA
	B85 @ 20.71 dBm	184.37	mA
	B1 @ 21.14 dBm	145.63	mA
	B2 @ 21.02 dBm	145.24	mA
	B3 @ 21.01 dBm	141.9	mA
	B4 @ 21.2 dBm	143.23	mA
	B5 @ 20.79 dBm	143	mA
LTE Cat NB1 data transfer (GNSS OFF)	B8 @ 20.86 dBm	156.34	mA
	B12 @ 21.02 dBm	149.72	mA
	B13 @ 21.03 dBm	150.06	mA
	B18 @ 20.79 dBm	142.77	mA
	B19 @ 21.12 dBm	146.11	mA

B20 @ 20.89 dBm	145.87	mA
B25 @ 21.09 dBm	147.17	mA
B28 @ 20.84 dBm	147.14	mA
B31 @ 22.07 dBm	146.57	mA
B31 @ 25.94 dBm	194.53	mA
B66 @ 20.94 dBm	140.97	mA
B72 @ 22.12 dBm	147.19	mA
B72 @ 26.07 dBm	195.16	mA
B73 @ 22.31 dBm	147.55	mA
B73 @ 25.89 dBm	192.77	mA
B85 @ 20.94 dBm	147.15	mA

Table 48: BG95-M5 Power Consumption (3.8 V Power Supply, Room Temperature)

Description	Conditions	Average	Unit
Leakage ¹⁸	Power-off @ USB and UART disconnected	14.87	μA
PSM ¹⁹	Power Saving Mode	5.10	μA
Rock Bottom	AT+CFUN=0 @ Sleep mode	0.587	mA
	LTE Cat M1 DRX = 1.28 s	1.56	mA
	LTE Cat NB1 DRX = 1.28 s	1.43	mA
	EGSM900 DRX = 5	1.21	mA
Sleep Mode (USB disconnected)	DCS1800 DRX = 5	1.17	mA
	LTE Cat M1 e-I-DRX = 81.92 s @ PTW = 2.56 s, DRX = 1.28 s	0.72	mA
	LTE Cat NB1 e-I-DRX = 81.92 s @ PTW = 2.56 s, DRX = 1.28 s	0.68	mA
Idle Mode	LTE Cat M1 DRX = 1.28 s	17.3	mA

(USB disconnected)	LTE Cat NB1 DRX = 1.28 s	13.5	mA
	LTE Cat M1 e-I-DRX = 81.92 s @ PTW = 2.56 s, DRX = 1.28 s	16.6	mA
	LTE Cat NB1 e-I-DRX = 81.92 s @ PTW = 2.56 s, DRX = 1.28 s	13.1	mA
LTE Cat M1 data transfer (GNSS OFF)	B1 @ 22.58 dBm	218.72	mA
	B2 @ 22.99 dBm	216.74	mA
	B3 @ 22.96 dBm	226.63	mA
	B4 @ 22.82 dBm	225.59	mA
	B5 @ 22.83 dBm	233.79	mA
	B8 @ 22.89 dBm	226.57	mA
	B12 @ 22.71 dBm	218.31	mA
	B13 @ 23 dBm	230.49	mA
	B18 @ 22.75 dBm	227.33	mA
	B19 @ 22.56 dBm	231.22	mA
	B20 @ 23.03 dBm	241.04	mA
	B25 @ 22.74 dBm	212.63	mA
	B26 @ 23.13 dBm	234.54	mA
	B27 @ 22.54 dBm	225.16	mA
	B28A @ 23.01 dBm	224.57	mA
B28B @ 23.29 dBm	231.88	mA	
B66 @ 22.76 dBm	219.52	mA	
B85 @ 23.02 dBm	220.6	mA	
LTE Cat NB1 data transfer (GNSS OFF)	B1 @ 22.59 dBm	183.76	mA
	B2 @ 23.15 dBm	188.56	mA
	B3 @ 23.04 dBm	194.29	mA

	B4 @ 22.75 dBm	198.68	mA
	B5 @ 22.87 dBm	197.07	mA
	B8 @ 22.79 dBm	189.49	mA
	B12 @ 22.83 dBm	179.76	mA
	B13 @ 23.07 dBm	196.98	mA
	B18 @ 22.6 dBm	192.52	mA
	B19 @ 22.62 dBm	192.24	mA
	B20 @ 23.15 dBm	200.01	mA
	B25 @ 22.95 dBm	185.15	mA
	B28 @ 22.93 dBm	178.48	mA
	B66 @ 23.07 dBm	198.04	mA
	B71 @ 23 dBm	178.59	mA
	B85 @ 23.03 dBm	177.56	mA
GPRS data transfer (GNSS OFF)	GSM850 4UL/1DL @ 29.43 dBm	598.33	mA
	EGSM900 4UL/1DL @ 28.76 dBm	564.27	mA
	DCS1800 4UL/1DL @ 25.83 dBm	440.14	mA
	PCS1900 4UL/1DL @ 25.81dBm	451.49	mA
EDGE data transfer (GNSS OFF)	GSM850 4UL/1DL @ 23.22 dBm	552.75	mA
	EGSM900 4UL/1DL @ 23.28 dBm	555.95	mA
	DCS1800 4UL/1DL @ 21.63 dBm	491.43	mA
	PCS1900 4UL/1DL @ 21.53 dBm	494.98	mA

Table 49: BG95-M6 Power Consumption (3.8 V Power Supply, Room Temperature)

Description	Conditions	Average	Unit
Leakage ¹⁸	Power-off @ USB and UART disconnected	13.57	μA
PSM ¹⁹	Power Saving Mode	4.32	μA
Rock Bottom	AT+CFUN=0 @ Sleep mode	0.473	mA
Sleep Mode (USB disconnected)	LTE Cat M1 DRX = 1.28 s	1.42	mA
	LTE Cat NB1 DRX = 1.28 s	1.31	mA
	LTE Cat M1 e-I-DRX = 81.92 s @ PTW = 2.56 s, DRX = 1.28 s	0.58	mA
	LTE Cat NB1 e-I-DRX = 81.92 s @ PTW = 2.56 s, DRX = 1.28 s	0.55	mA
	LTE Cat M1 DRX = 1.28 s	18.5	mA
Idle Mode (USB disconnected)	LTE Cat NB1 DRX = 1.28 s	14.2	mA
	LTE Cat M1 e-I-DRX = 81.92 s @ PTW = 2.56 s, DRX = 1.28 s	18.2	mA
	LTE Cat NB1 e-I-DRX = 81.92 s @ PTW = 2.56 s, DRX = 1.28 s	14	mA
	B1 @ 22.91 dBm	199.7	mA
LTE Cat M1 data transfer (GNSS OFF)	B2 @ 22.69 dBm	203.64	mA
	B3 @ 22.75 dBm	200.94	mA
	B4 @ 22.94 dBm	205.62	mA
	B5 @ 23.01 dBm	216.42	mA
	B8 @ 22.75 dBm	218.12	mA
	B12 @ 22.72 dBm	192.36	mA
	B13 @ 23.03 dBm	208.61	mA
B18 @ 22.5 dBm	210.15	mA	

	B19 @ 22.74 dBm	215.11	mA
	B20 @ 22.83 dBm	218.18	mA
	B25 @ 22.74 dBm	199.24	mA
	B26 @ 22.84 dBm	212.06	mA
	B27 @ 22.96 dBm	211.86	mA
	B28A @ 22.87 dBm	197.23	mA
	B28B @ 22.9 dBm	201.35	mA
	B66 @ 22.83 dBm	202.47	mA
	B85 @ 23.01 dBm	194.48	mA
	B1 @ 22.84 dBm	177.8	mA
	B2 @ 22.76 dBm	172.31	mA
	B3 @ 22.68 dBm	167.18	mA
	B4 @ 22.98 dBm	176.91	mA
	B5 @ 22.91 dBm	179.95	mA
	B8 @ 23.09 dBm	193.03	mA
	B12 @ 23.07 dBm	162.89	mA
	B13 @ 22.96 dBm	172.4	mA
LTE Cat NB1 data transfer (GNSS OFF)	B18 @ 22.73 dBm	175.49	mA
	B19 @ 22.95 dBm	181.95	mA
	B20 @ 22.98 dBm	187.71	mA
	B25 @ 22.87 dBm	172.34	mA
	B28 @ 22.96 dBm	163.55	mA
	B66 @ 23.13 dBm	178.54	mA
	B71 @ 23.1 dBm	160.7	mA
	B85 @ 23.02 dBm	161.07	mA

Table 50: BG95-MF Power Consumption (3.8 V Power Supply, Room Temperature)

Description	Conditions	Average	Unit
Leakage ¹⁸	Power-off @ USB and UART disconnected	13.79	μA
PSM ¹⁹	Power Saving Mode	4.04	μA
Rock Bottom	AT+CFUN=0 @ Sleep mode	0.511	mA
Sleep Mode (USB disconnected)	LTE Cat M1 DRX = 1.28 s	1.59	mA
	LTE Cat NB1 DRX = 1.28 s	1.43	mA
	LTE Cat M1 e-I-DRX = 81.92 s @ PTW = 2.56 s, DRX = 1.28 s	0.58	mA
	LTE Cat NB1 e-I-DRX = 81.92 s @ PTW = 2.56 s, DRX = 1.28 s	0.56	mA
	LTE Cat M1 DRX = 1.28 s	18.05	mA
Idle Mode (USB disconnected)	LTE Cat NB1 DRX = 1.28 s	14.22	mA
	LTE Cat M1 e-I-DRX = 81.92 s @ PTW = 2.56 s, DRX = 1.28 s	17.97	mA
	LTE Cat NB1 e-I-DRX = 81.92 s @ PTW = 2.56 s, DRX = 1.28 s	14.1	mA
	B1 @ 21.11 dBm	175.75	mA
LTE Cat M1 data transfer (GNSS OFF)	B2 @ 21.31 dBm	174.58	mA
	B3 @ 20.92 dBm	168.92	mA
	B4 @ 21.1 dBm	170.65	mA
	B5 @ 21.07 dBm	188.66	mA
	B8 @ 21.13 dBm	185.65	mA
	B12 @ 21.14 dBm	178.63	mA
	B13 @ 21.37 dBm	192.08	mA
	B18 @ 21.49 dBm	193.67	mA

	B19 @ 21.26 dBm	192.39	mA
	B20 @ 21.28 dBm	191.3	mA
	B25 @ 21.05 dBm	175.43	mA
	B26 @ 21.15 dBm	190.49	mA
	B27 @ 21.54 dBm	194.89	mA
	B28A @ 21.09 dBm	179.64	mA
	B28B @ 21.08 dBm	186.91	mA
	B66 @ 20.93 dBm	169.54	mA
	B85 @ 21.4 dBm	180.21	mA
	B1 @ 21.01 dBm	135.1	mA
	B2 @ 20.48 dBm	133.03	mA
	B3 @ 20.97 dBm	130.75	mA
	B4 @ 20.98 dBm	131.08	mA
	B5 @ 20.56 dBm	147.21	mA
	B8 @ 20.71 dBm	146.28	mA
	B12 @ 20.83 dBm	139.31	mA
	B13 @ 20.5 dBm	149.23	mA
LTE Cat NB1 data transfer (GNSS OFF)	B18 @ 20.89 dBm	151.5	mA
	B19 @ 21.12 dBm	153.53	mA
	B20 @ 21.04 dBm	153.86	mA
	B25 @ 20.98 dBm	135.14	mA
	B28 @ 21.4 dBm	142.85	mA
	B66 @ 20.8 dBm	128.62	mA
	B71 @ 20.93 dBm	131.08	mA
	B85 @ 21.04 dBm	136.76	mA

Table 51: BG95-M8 Power Consumption (3.8 V Power Supply, Room Temperature)

Description	Conditions	Average	Unit
Leakage ¹⁸	Power-off @ USB and UART disconnected	14.01	μA
PSM ¹⁹	Power Saving Mode	3.91	μA
Rock Bottom	AT+CFUN=0 @ Sleep mode	0.65	mA
	LTE Cat M1 DRX = 1.28 s	1.56	mA
	LTE Cat NB1 DRX = 1.28 s	1.51	mA
	EGSM900 DRX = 5	1.34	mA
Sleep Mode (USB disconnected)	DCS1800 DRX = 5	1.29	mA
	LTE Cat M1 e-I-DRX = 81.92 s @ PTW = 2.56 s, DRX = 1.28 s	0.73	mA
	LTE Cat NB1 e-I-DRX = 81.92 s @ PTW = 2.56 s, DRX = 1.28 s	0.78	mA
	LTE Cat M1 DRX = 1.28 s	14.64	mA
	LTE Cat NB1 DRX = 1.28 s	14.52	mA
Idle Mode (USB disconnected)	LTE Cat M1 e-I-DRX = 81.92 s @ PTW = 2.56 s, DRX = 1.28 s	14.17	mA
	LTE Cat NB1 e-I-DRX = 81.92 s @ PTW = 2.56 s, DRX = 1.28 s	14.16	mA
	B1 @ 21.11 dBm	184	mA
	B2 @ 20.91 dBm	188	mA
	B3 @ 20.98 dBm	182	mA
LTE Cat M1 data transfer (GNSS OFF)	B4 @ 21.01 dBm	182	mA
	B5 @ 20.95 dBm	184	mA
	B8 @ 21.0 dBm	190	mA
	B12 @ 21.0 dBm	180	mA

	B13 @ 20.99 dBm	193	mA
	B18 @ 20.69 dBm	186	mA
	B19 @ 20.72 dBm	187	mA
	B20 @ 20.56 dBm	184	mA
	B25 @ 20.68 dBm	180	mA
	B26 @ 20.95 dBm	188	mA
	B27 @ 21.04 dBm	188	mA
	B28A @ 20.93 dBm	183	mA
	B28B @ 20.93 dBm	182	mA
	B31 @ 26.29 dBm	262	mA
	B66 @ 21.01 dBm	181	mA
	B72 @ 26.11 dBm	257	mA
	B73 @ 25.27 dBm	255	mA
	B85 @ 20.88 dBm	182	mA
	B1 @ 21.61 dBm	149	mA
	B2 @ 21.08 dBm	136	mA
	B3 @ 21.02 dBm	143	mA
	B4 @ 21.59 dBm	151	mA
	B5 @ 21.33 dBm	159	mA
LTE Cat NB1 data transfer (GNSS OFF)	B8 @ 21.35 dBm	160	mA
	B12 @ 21.46 dBm	146	mA
	B13 @ 21.09 dBm	162	mA
	B18 @ 21.2 dBm	154	mA
	B19 @ 21.17 dBm	156	mA
	B20 @ 21.1 dBm	156	mA

	B25 @ 21.27 dBm	153	mA
	B28 @ 21.19 dBm	156	mA
	B31 @ 25.92 dBm	235	mA
	B66 @ 20.85 dBm	152	mA
	B72 @ 26.09 dBm	236	mA
	B73 @ 25.95 dBm	230	mA
	B85 @ 21.0 dBm	147	mA
GPRS data transfer (GNSS OFF)	GSM850 4UL/1DL @ 28.01 dBm	577	mA
	GSM900 4UL/1DL @ 27.94 dBm	575	mA
	DCS1800 4UL/1DL @ 25.74 dBm	446	mA
	PCS1900 4UL/1DL @ 25.69 dBm	451	mA
EDGE data transfer (GNSS OFF)	GSM850 4UL/1DL @ 21.50 dBm	547	mA
	GSM900 4UL/1DL @ 21.28 dBm	552	mA
	DCS1800 4UL/1DL @ 21.34 dBm	473	mA
	PCS1900 4UL/1DL @ 21.25 dBm	479	mA

Table 52: BG95-M9 Power Consumption (3.8 V Power Supply, Room Temperature)

Description	Conditions	Average	Unit
Leakage ¹⁸	Power-off @ USB and UART disconnected	15.12	μA
PSM ¹⁹	Power Saving Mode	4.44	μA
Rock Bottom	AT+CFUN=0 @ Sleep mode	0.59	mA
Sleep Mode (USB disconnected)	LTE Cat M1 DRX = 1.28 s	1.37	mA
	LTE Cat NB1 DRX = 1.28 s	1.36	mA
	LTE Cat M1 e-I-DRX = 81.92 s @ PTW = 2.56 s, DRX = 1.28 s	0.62	mA

	LTE Cat NB1 e-I-DRX = 81.92 s @ PTW = 2.56 s, DRX = 1.28 s	0.72	mA
	LTE Cat M1 DRX = 1.28 s	14.49	mA
	LTE Cat NB1 DRX = 1.28 s	14.78	mA
Idle Mode (USB disconnected)	LTE Cat M1 e-I-DRX = 81.92 s @ PTW = 2.56 s, DRX = 1.28 s	13.92	mA
	LTE Cat NB1 e-I-DRX = 81.92 s @ PTW = 2.56 s, DRX = 1.28 s	13.93	mA
	B1 @ 22.85 dBm	215.48	mA
	B2 @ 23.15 dBm	208.04	mA
	B3 @ 23.11 dBm	206.09	mA
	B4 @ 22.93 dBm	205.30	mA
	B5 @ 22.67 dBm	209.33	mA
	B8 @ 22.47 dBm	211.97	mA
	B12 @ 22.95 dBm	208.88	mA
	B13 @ 22.50 dBm	198.00	mA
LTE Cat M1 data transfer (GNSS OFF)	B18 @ 22.07 dBm	202.10	mA
	B19 @ 22.55 dBm	207.05	mA
	B20 @ 22.10 dBm	207.85	mA
	B25 @ 23.0 dBm	203.85	mA
	B26 @ 22.52 dBm	206.96	mA
	B27 @ 22.20 dBm	201.60	mA
	B28A @ 23.09 dBm	205.80	mA
	B28B @ 23.08 dBm	204.63	mA
	B31 @ 26.02 dBm	280.00	mA
	B66 @ 23.32 dBm	209.61	mA

	B72 @ 25.96 dBm	283.00	mA
	B73 @ 26.24 dBm	282.00	mA
	B85 @ 23.05 dBm	200.66	mA
	B87 @ 22.87 dBm	210.19	mA
	B88 @ 22.88 dBm	211.54	mA
	B1 @ 22.68 dBm	179.66	mA
	B2 @ 22.51 dBm	173.42	mA
	B3 @ 22.90 dBm	168.97	mA
	B4 @ 22.79 dBm	172.22	mA
	B5 @ 23.28 dBm	184.91	mA
	B8 @ 22.73 dBm	185.95	mA
	B12 @ 23.32 dBm	174.42	mA
	B13 @ 23.16 dBm	174.09	mA
	B18 @ 23.22 dBm	181.01	mA
LTE Cat NB1 data transfer (GNSS OFF)	B19 @ 22.94 dBm	180.93	mA
	B20 @ 23.11 dBm	186.44	mA
	B25 @ 23.48 dBm	182.10	mA
	B28 @ 23.22 dBm	173.08	mA
	B31 @ 26.07 dBm	269.00	mA
	B66 @ 22.55 dBm	174.00	mA
	B72 @ 26.04 dBm	263.00	mA
	B73 @ 25.96 dBm	256.00	mA
	B85 @ 23.11 dBm	166.67	mA
	B86 @ 23.01 dBm	171.10	mA
	B87 @ 23.04 dBm	183.63	mA

B88 @ 22.98 dBm 181.52 mA

Table 53: GNSS Power Consumption of BG95-M1 (3.3 V Power Supply, Room Temperature)

Description	Conditions	Typ.	Unit
Acquisition (AT+CFUN=0)	Cold start @ Instrument	76.74	mA
	Hot start @ Instrument	74.04	mA
	Warm start @ Instrument	76.19	mA
	Lost state @ Instrument	76.05	mA
Tracking (AT+CFUN=0)	Instrument environment @ Passive antenna	23.14	mA
	Open sky @ Real network, Passive antenna	26.352	mA
	Open sky @ Real network, Active antenna	27.463	mA

Table 54: GNSS Power Consumption of BG95-M2 (3.3 V Power Supply, Room Temperature)

Description	Conditions	Typ.	Unit
Acquisition (AT+CFUN=0)	Cold start @ Instrument	76.74	mA
	Hot start @ Instrument	74.04	mA
	Warm start @ Instrument	76.19	mA
	Lost state @ Instrument	76.05	mA
Tracking (AT+CFUN=0)	Instrument environment @ Passive antenna	25.17	mA
	Open sky @ Real network, Passive antenna	22.717	mA
	Open sky @ Real network, Active antenna	25.698	mA

Table 55: GNSS Power Consumption of BG95-M3 (3.8 V Power Supply, Room Temperature)

Description	Conditions	Typ.	Unit
Acquisition (AT+CFUN=0)	Cold start @ Instrument	70.00	mA
	Hot start @ Instrument	73.66	mA
	Warm start @ Instrument	72.54	mA
	Lost state @ Instrument	69.24	mA
Tracking (AT+CFUN=0)	Instrument environment @ Passive antenna	22.31	mA
	Open sky @ Real network, Passive antenna	21.792	mA
	Open sky @ Real network, Active antenna	22.357	mA

Table 56: GNSS Power Consumption of BG95-M4 (3.8 V Power Supply, Room Temperature)

Description	Conditions	Typ.	Unit
Acquisition (AT+CFUN=0)	Cold start @ Instrument	64.90	mA
	Hot start @ Instrument	63.30	mA
	Warm start @ Instrument	64.47	mA
	Lost state @ Instrument	65.74	mA
Tracking (AT+CFUN=0)	Instrument environment @ Passive antenna	20.2	mA
	Open sky @ Real network, Passive antenna	23.045	mA
	Open sky @ Real network, Active antenna	23.173	mA

Table 57: GNSS Power Consumption of BG95-M5 (3.8 V Power Supply, Room Temperature)

Description	Conditions	Typ.	Unit
Acquisition (AT+CFUN=0)	Cold start @ Instrument	67.12	mA
	Hot start @ Instrument	65.98	mA
	Warm start @ Instrument	66.46	mA
	Lost state @ Instrument	67.62	mA
Tracking (AT+CFUN=0)	Instrument environment @ Passive antenna	27.95	mA
	Open sky @ Real network, Passive antenna	22.723	mA
	Open sky @ Real network, Active antenna	23.529	mA

Table 58: GNSS Power Consumption of BG95-M6 (3.8 V Power Supply, Room Temperature)

Description	Conditions	Typ.	Unit
Acquisition (AT+CFUN=0)	Cold start @ Instrument	65.54	mA
	Hot start @ Instrument	64.04	mA
	Warm start @ Instrument	65.37	mA
	Lost state @ Instrument	66.96	mA
Tracking (AT+CFUN=0)	Instrument environment @ Passive antenna	30.51	mA
	Open sky @ Real network, Passive antenna	21.608	mA
	Open sky @ Real network, Active antenna	27.773	mA

Table 59: GNSS Power Consumption of BG95-MF (3.8 V Power Supply, Room Temperature)

Description	Conditions	Typ.	Unit
Acquisition (AT+CFUN=0)	Cold start @ Instrument	69.72	mA
	Hot start @ Instrument	64.13	mA
	Warm start @ Instrument	70.81	mA
	Lost state @ Instrument	67.14	mA
Tracking (AT+CFUN=0)	Instrument environment @ Passive antenna	22.33	mA
	Open sky @ Real network, Passive antenna	20.065	mA
	Open sky @ Real network, Active antenna	21.829	mA

Table 60: GNSS Power Consumption of BG95-M8 (3.8 V Power Supply, Room Temperature)

Description	Conditions	Typ.	Unit
Acquisition (AT+CFUN=0)	Cold start @ Instrument	69.00	mA
	Hot start @ Instrument	69.18	mA
	Warm start @ Instrument	69.05	mA
	Lost state @ Instrument	68.01	mA
Tracking (AT+CFUN=0)	Instrument Environment @ Passive Antenna	20.52	mA
	Open Sky @ Real network, Passive Antenna	21.95	mA
	Open Sky @ Real network, Active Antenna	22.31	mA

Table 61: GNSS Power Consumption of BG95-M9 (3.8 V Power Supply, Room Temperature)

Description	Conditions	Typ.	Unit
Acquisition (AT+CFUN=0)	Cold start @ Instrument	61.20	mA
	Hot start @ Instrument	67.41	mA
	Warm start @ Instrument	60.09	mA
	Lost state @ Instrument	57.17	mA
Tracking (AT+CFUN=0)	Instrument Environment @ Passive Antenna	20.13	mA
	Open Sky @ Real network, Passive Antenna	21.36	mA
	Open Sky @ Real network, Active Antenna	21.66	mA

Table 62: Wi-Fi Power Consumption of BG95-MF (3.8 V Power Supply, Room Temperature)

Description	Conditions	Typ.	Unit
Acquisition (AT+CFUN=0)	Wi-Fi OFF (Module in sleep mode)	1.30	mA
	Wi-Fi OFF (Module in idle mode)	8.49	mA
	Wi-Fi ON (no scan)	78.5	mA
	Wi-Fi ON (Scan hotspots nearby)	80.84	mA
Scan	Wi-Fi ON (Get location)	16.80	mA

6.5. Tx Power

Table 63: Conducted Tx Power of BG95-M1/-M2/-M3/-MF

Frequency Bands	Max. Tx Power	Min. Tx Power
LTE HD-FDD B1/B2/B3/B4/B5/B8/B12/B13/B18/B19/B20/ B25/B26/B27/B28/B66/B71/B85	21 dBm +1.7/-3 dB	< -39 dBm
GSM850/EGSM900	33 dBm ±2 dB	5 dBm ±5 dB

DCS1800/PCS1900	30 dBm ±2 dB	0 dBm ±5 dB
GSM850/EGSM900 (8-PSK)	27 dBm ±3 dB	5 dBm ±5 dB
DCS1800/PCS1900 (8-PSK)	26 dBm ±3 dB	0 dBm ±5 dB

Table 64: Conducted Tx Power of BG95-M4

Frequency Bands	Max. Tx Power	Min. Tx Power
LTE HD-FDD B1/B2/B3/B4/B5/B8/B12/B13/B18/B19/B20/ B25/B26/B27/B28/B66/B85	21 dBm +1.7/-3 dB	< -39 dBm
LTE HD-FDD B31/B72/B73@ Power Class 2	26 dBm ±2 dB	< -39 dBm
LTE HD-FDD B31/B72/B73@ Power Class 3	23 dBm ±2 dB	< -39 dBm

Table 65: Conducted Tx Power of BG95-M5/-M6

Frequency Bands	Max. Tx Power	Min. Tx Power
LTE HD-FDD B1/B2/B3/B4/B5/B8/B12/B13/B18/B19/B20/ B25/B26/B27/B28/B66/B71/B85	23 dBm ±2 dB	< -39 dBm
GSM850/EGSM900	33 dBm ±2 dB	5 dBm ±5 dB
DCS1800/PCS1900	30 dBm ±2 dB	0 dBm ±5 dB
GSM850/EGSM900 (8-PSK)	27 dBm ±3 dB	5 dBm ±5 dB
DCS1800/PCS1900 (8-PSK)	26 dBm ±3 dB	0 dBm ±5 dB

Table 66: Conducted Tx Power of BG95-M8

Frequency Bands	Max. Tx Power	Min. Tx Power
LTE HD-FDD B1/B2/B3/B4/B5/B8/B12/B13/B18/B19/B20/ B25/B26/B27/B28/B66/B85	21 dBm +1.7/-3 dB	< -39 dBm
LTE HD-FDD B31/B72/B73	26 dBm ±2 dB	< -39 dBm
GSM850/EGSM900	33 dBm ±2 dB	5 dBm ±5 dB

DCS1800/PCS1900	30 dBm ±2 dB	0 dBm ±5 dB
GSM850/EGSM900 (8-PSK)	27 dBm ±3 dB	5 dBm ±5 dB
DCS1800/PCS1900 (8-PSK)	26 dBm ±3 dB	0 dBm ±5 dB

Table 67: Conducted Tx Power of BG95-M9

Frequency Bands	Max. Tx Power	Min. Tx Power
LTE HD-FDD B1/B2/B3/B4/B5/B8/B12/B13/B18/B19/B20/ B25/B26/B27/B28/B66//B85/B86/B87/B88	23 dBm ±2 dB	< -39 dBm
B31/B72/B73	26 dBm ±2 dB	< -39 dBm

NOTE

1. LTE HD-FDD B26 and B27 are supported by Cat M1 only.
2. LTE HD-FDD B31, B72 and B73 are supported by BG95-M4, BG95-M8 and BG95-M9. For BG95-M4, LTE HD-FDD B31, B72 and B73 supports Power Class 2 (26 dBm) and Power Class 3 (23 dBm).
3. LTE HD-FDD B71 is supported by Cat NB2 only.
4. For GPRS transmission on 4 uplink timeslots, the maximum output power reduction is 4.0 dB. The design conforms to *3GPP TS 51.010-1 subclause 13.16*.

6.6. Rx Sensitivity

Table 68: Conducted Rx Sensitivity of BG95-M1

Mode	Band	Primary	Diversity	Rx Sensitivity (dBm)	
				Cat M1/3GPP	Cat NB2
LTE	LTE HD-FDD B1	Supported	-	-108/-102.3	-
	LTE HD-FDD B2			-108.4/-100.3	-
	LTE HD-FDD B3			-108.4/-99.3	-
	LTE HD-FDD B4			-108/-102.3	-

LTE HD-FDD B5	-107.6/-100.8
LTE HD-FDD B8	-108/-99.8
LTE HD-FDD B12	-108.6/-99.3
LTE HD-FDD B13	-107/-99.3
LTE HD-FDD B18	-108/-102.3
LTE HD-FDD B19	-108/-102.3
LTE HD-FDD B20	-108/-99.8
LTE HD-FDD B25	-108.2/-100.3
LTE HD-FDD B26	-108.2/-100.3
LTE HD-FDD B27	-108.4/-100.8
LTE HD-FDD B28	-106.8/-100.8
LTE HD-FDD B66	-107.8/-101.8
LTE HD-FDD B71	-
LTE HD-FDD B85	-108.4/-99.3

Table 69: Conducted Rx Sensitivity of BG95-M2

Mode	Band	Primary	Diversity	Rx Sensitivity (dBm)	
				Cat M1/3GPP	Cat NB2 ²⁰ /3GPP
LTE	LTE HD-FDD B1	Supported	-	-107/-102.3	-114/-107.5
	LTE HD-FDD B2			-107/-100.3	-116/-107.5
	LTE HD-FDD B3			-107/-99.3	-113/-107.5
	LTE HD-FDD B4			-107/-102.3	-114/-107.5
	LTE HD-FDD B5			-107/-100.8	-115/-107.5
	LTE HD-FDD B8			-107/-99.8	-113/-107.5

²⁰ 3GPP has made no requirements for LTE Cat NB Rx Sensitivity repetition.

LTE HD-FDD B12	-107/-99.3	-116/-107.5
LTE HD-FDD B13	-107/-99.3	-114/-107.5
LTE HD-FDD B18	-107/-102.3	-116/-107.5
LTE HD-FDD B19	-107/-102.3	-116/-107.5
LTE HD-FDD B20	-107/-99.8	-115/-107.5
LTE HD-FDD B25	-107/-100.3	-115/-107.5
LTE HD-FDD B26	-107/-100.3	-
LTE HD-FDD B27	-107/-100.8	-
LTE HD-FDD B28	-107/-100.8	-115/-107.5
LTE HD-FDD B66	-107/-101.8	-115/-107.5
LTE HD-FDD B71	-	-115/-107.5
LTE HD-FDD B85	-107/-99.3	-115/-107.5

Table 70: Conducted Rx Sensitivity of BG95-M3

Mode	Band	Primary	Diversity	Rx Sensitivity (dBm)	
				Cat M1/3GPP	Cat NB2 20/3GPP
LTE	LTE HD-FDD B1	Supported	-	-106.5/-102.3	-113/-107.5
	LTE HD-FDD B2			-106/-100.3	-114/-107.5
	LTE HD-FDD B3			-106/-99.3	-114/-107.5
	LTE HD-FDD B4			-106.5/-102.3	-114/-107.5
	LTE HD-FDD B5			-106/-100.8	-115/-107.5
	LTE HD-FDD B8			-106/-99.8	-114/-107.5
	LTE HD-FDD B12			-106.5/-99.3	-115/-107.5
	LTE HD-FDD B13			-106.5/-99.3	-115/-107.5
	LTE HD-FDD B18			-106/-102.3	-115/-107.5

LTE HD-FDD B19	-106/-102.3	-115/-107.5
LTE HD-FDD B20	-106/-99.8	-114/-107.5
LTE HD-FDD B25	-106/-100.3	-114/-107.5
LTE HD-FDD B26	-106/-100.3	-
LTE HD-FDD B27	-106.5/-100.8	-
LTE HD-FDD B28	-106/-100.8	-115/-107.5
LTE HD-FDD B66	-106.5/-101.8	-114/-107.5
LTE HD-FDD B71	-	-115/-107.5
LTE HD-FDD B85	-106.5/-99.3	-115/-107.5

Mode	Band	Primary	Diversity	Rx Sensitivity (dBm)	
				GSM/3GPP	
GPRS (CS2)	GSM850/EGSM900	Supported	-	-107/-102	
	DCS1800/PCS1900			-107/-102	

Table 71: Conducted Rx Sensitivity of BG95-M4

Mode	Band	Primary	Diversity	Rx Sensitivity (dBm)	
				Cat M1/3GPP	Cat NB2 ²⁰ /3GPP
LTE	LTE HD-FDD B1	Supported	-	-105.3/-102.3	-116/-107.5
	LTE HD-FDD B2			-103.3/-100.3	-116/-107.5
	LTE HD-FDD B3			-102.3/-99.3	-117/-107.5
	LTE HD-FDD B4			-105.3/-102.3	-116/-107.5
	LTE HD-FDD B5			-103.8/-100.8	-116/-107.5
	LTE HD-FDD B8			-103.3/-99.8	-116/-107.5
	LTE HD-FDD B12			-102.3/-99.3	-117/-107.5
	LTE HD-FDD B13			-101.8/-99.3	-116/-107.5

LTE HD-FDD B18	-105.3/-102.3	-116/-107.5
LTE HD-FDD B19	-105.3/-102.3	-116/-107.5
LTE HD-FDD B20	-102.8/-99.8	-116/-107.5
LTE HD-FDD B25	-102.8/-100.3	-116/-107.5
LTE HD-FDD B26	-103.3/-100.3	-
LTE HD-FDD B27	-103.8/-100.8	-
LTE HD-FDD B28	-103.8/-100.8	-117/-107.5
LTE HD-FDD B31	-99.6/-96.6	-116/-107.5
LTE HD-FDD B66	103.8/-101.8	-116/-107.5
LTE HD-FDD B72	-99.6/-96.6	-116/-107.5
LTE HD-FDD B73	-99.6/-96.6	-116/-107.5
LTE HD-FDD B85	-102.3/-99.3	-116/-107.5

Table 72: Conducted Rx Sensitivity of BG95-M5

Mode	Band	Primary	Diversity	Rx Sensitivity (dBm)	
				Cat M1/3GPP	Cat NB2 ²⁰ /3GPP
LTE	LTE HD-FDD B1	Supported	-	-106.5/-102.3	-114/-107.5
	LTE HD-FDD B2			-107.5/-100.3	-115/-107.5
	LTE HD-FDD B3			-108.0/-99.3	-114/-107.5
	LTE HD-FDD B4			-108.0/-102.3	-114/-107.5
	LTE HD-FDD B5			-107.5/-100.8	-114/-107.5
	LTE HD-FDD B8			-106.5/-99.8	-114/-107.5
	LTE HD-FDD B12			-106.5/-99.3	-114/-107.5
	LTE HD-FDD B13			-107.5/-99.3	-114/-107.5
	LTE HD-FDD B18			-107.5/-102.3	-115/-107.5

LTE HD-FDD B19	-107.5/-102.3	-114/-107.5
LTE HD-FDD B20	-107.5/-99.8	-114/-107.5
LTE HD-FDD B25	-107.5/-100.3	-114/-107.5
LTE HD-FDD B26	-107.5/-100.3	-
LTE HD-FDD B27	-107.5/-100.8	-
LTE HD-FDD B28	-107.5/-100.8	-114/-107.5
LTE HD-FDD B66	-107.5/-101.8	-114/-107.5
LTE HD-FDD B71	-	-115/-107.5
LTE HD-FDD B85	-107.5/-99.3	-114/-107.5

Mode	Band	Primary	Diversity	Rx Sensitivity (dBm)	
				GSM/3GPP	
GPRS (CS2)	GSM850/EGSM900	Supported	-	-107/-102	
	DCS1800/PCS1900			-107/-102	

Table 73: Conducted Rx Sensitivity of BG95-M6

Mode	Band	Primary	Diversity	Rx Sensitivity (dBm)	
				Cat M1/3GPP	Cat NB2 ²⁰ /3GPP
LTE	LTE HD-FDD B1	Supported	-	-106.5/-102.3	-114/-107.5
	LTE HD-FDD B2			-107/-100.3	-115/-107.5
	LTE HD-FDD B3			-107/-99.3	-114/-107.5
	LTE HD-FDD B4			-106.5/-102.3	-114/-107.5
	LTE HD-FDD B5			-107.5/-100.8	-115/-107.5
	LTE HD-FDD B8			-107.5/-99.8	-115/-107.5
	LTE HD-FDD B12			-107.5/-99.3	-115/-107.5
	LTE HD-FDD B13			-107.5/-99.3	-115/-107.5

LTE HD-FDD B18	-107.5/-102.3	-115/-107.5
LTE HD-FDD B19	-107.5/-102.3	-115/-107.5
LTE HD-FDD B20	-107.5/-99.8	-114/-107.5
LTE HD-FDD B25	-107.5/-100.3	-114/-107.5
LTE HD-FDD B26	-107.5/-100.3	-
LTE HD-FDD B27	-107.5/-100.8	-
LTE HD-FDD B28	-107.5/-100.8	-115/-107.5
LTE HD-FDD B66	-107.5/-101.8	-114/-107.5
LTE HD-FDD B71	-	-115/-107.5
LTE HD-FDD B85	-107.5/-99.3	-115/-107.5

Table 74: Conducted Rx Sensitivity of BG95-MF

Mode	Band	Primary	Diversity	Rx Sensitivity (dBm)	
				Cat M1/3GPP	Cat NB2 ²⁰ /3GPP
LTE	LTE HD-FDD B1	Supported	-	-108/-102.3	-115/-107.5
	LTE HD-FDD B2			-108/-100.3	-115/-107.5
	LTE HD-FDD B3			-107/-99.3	-115/-107.5
	LTE HD-FDD B4			-108/-102.3	-115/-107.5
	LTE HD-FDD B5			-108/-100.8	-115/-107.5
	LTE HD-FDD B8			-107 /-99.8	-115/-107.5
	LTE HD-FDD B12			-108/-99.3	-115/-107.5
	LTE HD-FDD B13			-108/-99.3	-115/-107.5
	LTE HD-FDD B18			-108/-102.3	-115/-107.5
	LTE HD-FDD B19			-107/-102.3	-115/-107.5
	LTE HD-FDD B20			-108/-99.8	-115/-107.5

LTE HD-FDD B25	-108/-100.3	-115/-107.5
LTE HD-FDD B26	-108/-100.3	-
LTE HD-FDD B27	-108/-100.8	-
LTE HD-FDD B28	-108/-100.8	-115/-107.5
LTE HD-FDD B66	-108/-101.8	-115/-107.5
LTE HD-FDD B71	-	-115/-107.5
LTE HD-FDD B85	-108/-99.3	-115/-107.5

Table 75: Wi-Fi Conducted Rx Sensitivity of BG95-MF

Wi-Fi	Standard	Rate	Rx Sensitivity
2.4 GHz	802.11b	1 Mbps	-93 dBm
	802.11b	11 Mbps	-88 dBm
	802.11g	6 Mbps	-90 dBm
	802.11g	54 Mbps	-74 dBm
	802.11n HT20	MCS0	-89 dBm
	802.11n HT20	MCS7	-70 dBm

Table 76: Conducted Rx Sensitivity of BG95-M8

Mode	Band	Primary	Diversity	Receiver Sensitivity (dBm)	
				Cat M1/3GPP	Cat NB2 ²⁰ /3GPP
LTE	LTE HD-FDD B1	Supported	-	-106.5/-102.3	-115/-107.5
	LTE HD-FDD B2			-107.0/-100.3	-115/-107.5
	LTE HD-FDD B3			-107.0/-99.3	-115/-107.5
	LTE HD-FDD B4			-106.5/-102.3	-115/-107.5
	LTE HD-FDD B5			-107.5/-100.8	-116/-107.5
	LTE HD-FDD B8			-107.5/-99.8	-116/-107.5

LTE HD-FDD B12	-108.0/-99.3	-116/-107.5
LTE HD-FDD B13	-108.0/-99.3	-116/-107.5
LTE HD-FDD B18	-108.0/-102.3	-116/-107.5
LTE HD-FDD B19	-107.5/-102.3	-116/-107.5
LTE HD-FDD B20	-107.5/-99.8	-116/-107.5
LTE HD-FDD B25	-106.5/-100.3	-115/-107.5
LTE HD-FDD B26	-107.5/-100.3	-
LTE HD-FDD B27	-107.5/-100.8	-
LTE HD-FDD B28	-108.0/-100.8	-116/-107.5
LTE HD-FDD B31	-107.0/-96.6	-115/-107.5
LTE HD-FDD B66	-106.5/-101.8	-115/-107.5
LTE HD-FDD B72	-106.0/-96.6	-115/-107.5
LTE HD-FDD B73	-106.0/-96.6	-115/-107.5
LTE HD-FDD B85	-108.0/-99.3	-115/-107.5

Mode	Band	Primary	Diversity	Receiver Sensitivity (dBm)	
				GSM/3GPP	
GPRS (CS2)	GSM850/EGSM900	Supported	-	-107/-102	
	DCS1800/PCS1900			-107/-102	

Table 77: Conducted Rx Sensitivity of BG95-M9

Mode	Band	Primary	Diversity	Receiver Sensitivity (dBm)	
				Cat M1/3GPP	Cat NB2 ²⁰ /3GPP
LTE	LTE HD-FDD B1	Supported	-	-107.3/-102.3	-116/-107.5
	LTE HD-FDD B2			-107.3/-100.3	-116/-107.5
	LTE HD-FDD B3			-107.3/-99.3	-116/-107.5
	LTE HD-FDD B4			-107.3/-102.3	-116/-107.5

LTE HD-FDD B5	-107.8/-100.8	-116/-107.5
LTE HD-FDD B8	-107.8/-99.8	-116/-107.5
LTE HD-FDD B12	-108.3/-99.3	-116/-107.5
LTE HD-FDD B13	-108.8/-99.3	-116/-107.5
LTE HD-FDD B18	-107.3/-102.3	-116/-107.5
LTE HD-FDD B19	-107.3/-102.3	-116/-107.5
LTE HD-FDD B20	-107.8/-99.8	-116/-107.5
LTE HD-FDD B25	-107.8/-100.3	-116/-107.5
LTE HD-FDD B26	-107.8/-100.3	-
LTE HD-FDD B27	-107.7/-100.8	-
LTE HD-FDD B28	-107.8/-100.8	-116/-107.5
LTE HD-FDD B31	-107.8/-96.6	-116/-107.5
LTE HD-FDD B66	-106.8/-101.8	-116/-107.5
LTE HD-FDD B72	-107.8/-96.6	-116/-107.5
LTE HD-FDD B73	-107.8/-96.6	-116/-107.5
LTE HD-FDD B85	-108.3/-99.3	-116/-107.5
LTE HD-FDD B86	-	-117/-107.5
LTE HD-FDD B87	-106.6/-96.6	-115/-107.5
LTE HD-FDD B88	-106.6/-96.6	-115/-107.5

NOTE

-: not supported.

6.7. ESD Protection

Static electricity occurs naturally and it may damage the module. Therefore, it is imperative to adopt proper ESD countermeasures and handling methods. For example, wear anti-static gloves during the development, production, assembly and testing of the module; add ESD protection components to the ESD sensitive interfaces and points in the product design.

Table 78: Electrostatic Discharge Characteristics (Temperature: 25–30 °C, Humidity: 40 ±5 %)

Tested Interfaces	Contact Discharge	Air Discharge	Unit
VBAT, GND	±6	±8	kV
Main/GNSS Antenna Interfaces	±5	±6	kV

7 Mechanical Dimensions

This chapter describes the mechanical dimensions of the module. All dimensions are measured in millimeter (mm), and the dimensional tolerances are ± 0.2 mm unless otherwise specified.

7.1. Mechanical Dimensions

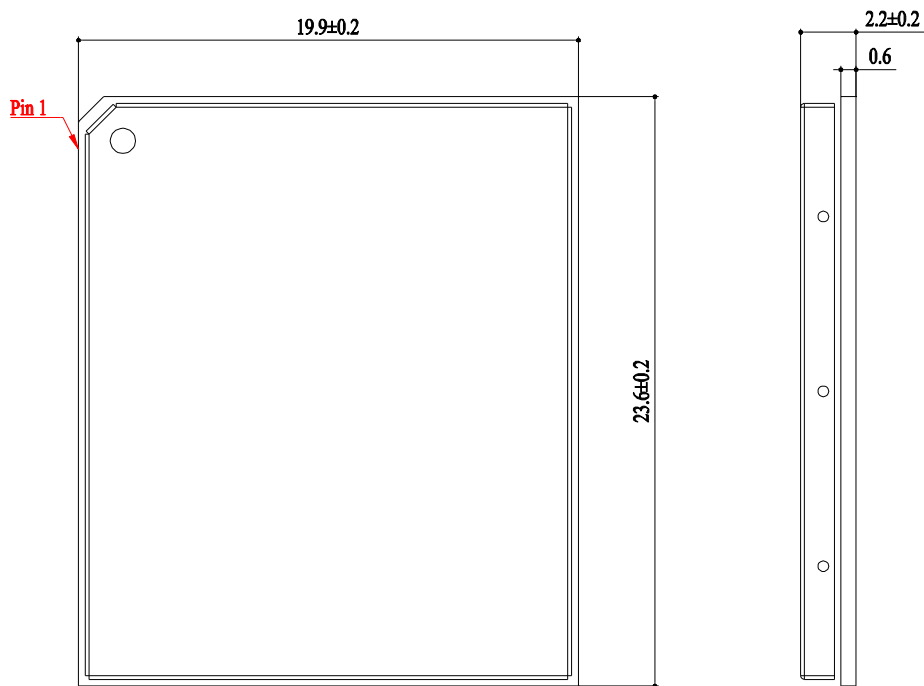

Figure 44: Module Top and Side Dimensions

7.3. Top and Bottom Views

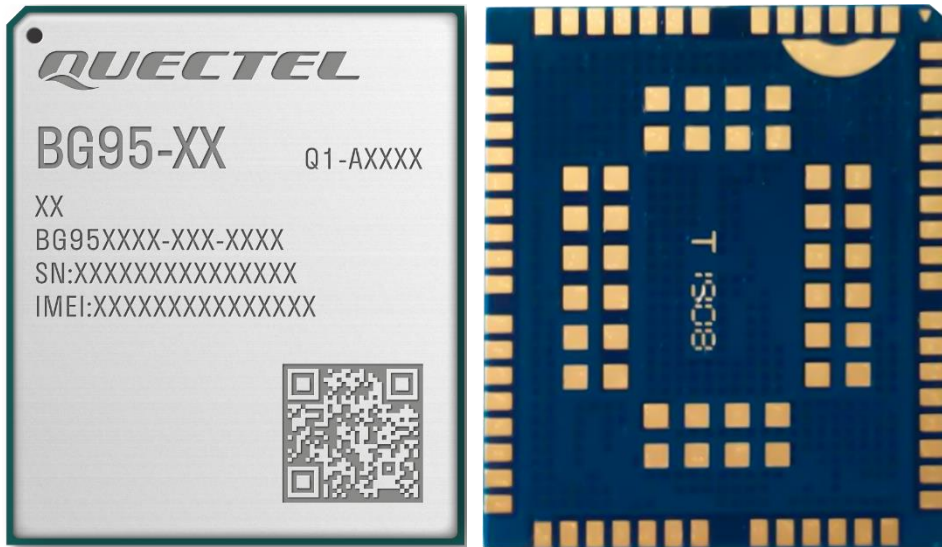

Figure 47: Top and Bottom Views

NOTE

Images above are for illustration purpose only and may differ from the actual module. For authentic appearance and label, please refer to the module received from Quectel.

8 Storage, Manufacturing and Packaging

8.1. Storage Conditions

The module is provided with vacuum-sealed packaging. MSL of the module is rated as 3. The storage requirements are shown below.

1. Recommended Storage Condition: the temperature should be 23 ± 5 °C and the relative humidity should be 35–60 %.
2. Shelf life (in a vacuum-sealed packaging): 12 months in Recommended Storage Condition.
3. Floor life: 168 hours ²¹ in a factory where the temperature is 23 ± 5 °C and relative humidity is below 60 %. After the vacuum-sealed packaging is removed, the module must be processed in reflow soldering or other high-temperature operations within 168 hours. Otherwise, the module should be stored in an environment where the relative humidity is less than 10 % (e.g., a dry cabinet).
4. The module should be pre-baked to avoid blistering, cracks and inner-layer separation in PCB under the following circumstances:
 - The module is not stored in Recommended Storage Condition;
 - Violation of the third requirement mentioned above;
 - Vacuum-sealed packaging is broken, or the packaging has been removed for over 24 hours;
 - Before module repairing.
5. If needed, the pre-baking should follow the requirements below:
 - The module should be baked for 8 hours at 120 ± 5 °C;
 - The module must be soldered to PCB within 24 hours after the baking, otherwise it should be put in a dry environment such as in a dry cabinet.

²¹ This floor life is only applicable when the environment conforms to *IPC/JEDEC J-STD-033*. It is recommended to start the solder reflow process within 24 hours after the package is removed if the temperature and moisture do not conform to, or are not sure to conform to *IPC/JEDEC J-STD-033*. Do not unpack the modules in large quantities until they are ready for soldering.

NOTE

1. To avoid blistering, layer separation and other soldering issues, extended exposure of the module to the air is forbidden.
2. Take out the module from the package and put it on high-temperature-resistant fixtures before baking. If shorter baking time is desired, see *IPC/JEDEC J-STD-033* for the baking procedure.
3. Pay attention to ESD protection, such as wearing anti-static gloves, when touching the modules.

8.2. Manufacturing and Soldering

Push the squeegee to apply the solder paste on the surface of stencil, thus making the paste fill the stencil openings and then penetrate to the PCB. Apply proper force on the squeegee to produce a clean stencil surface on a single pass. To guarantee module soldering quality, the thickness of stencil for the module is recommended to be 0.13–0.15 mm. For more details, see **document [8]**.

The recommended peak reflow temperature should be 235–246 °C, with 246 °C as the absolute maximum reflow temperature. To avoid damage to the module caused by repeated heating, it is recommended that the module should be mounted only after reflow soldering for the other side of PCB has been completed. The recommended reflow soldering thermal profile (lead-free reflow soldering) and related parameters are shown below.

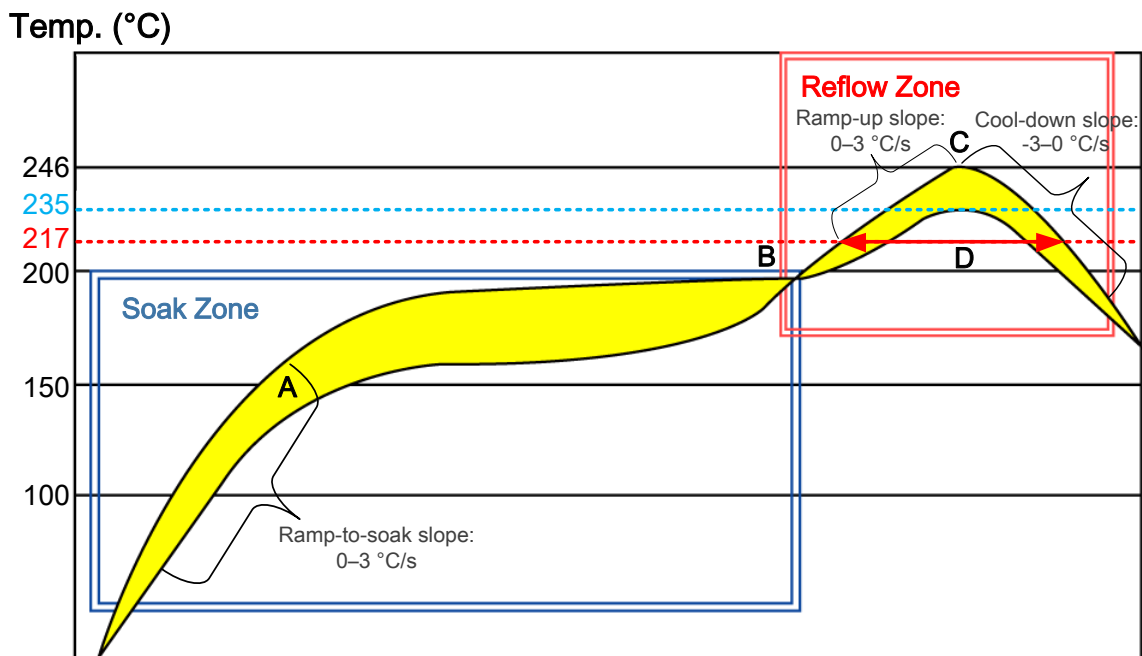

Figure 48: Recommended Reflow Soldering Thermal Profile

Table 79: Recommended Thermal Profile Parameters

Factor	Recommended Value
Soak Zone	
Ramp-to-soak slope	0–3 °C/s
Soak time (between A and B: 150 °C and 200 °C)	70–120 s
Reflow Zone	
Ramp-up slope	0–3 °C/s
Reflow time (D: over 217 °C)	40–70 s
Max temperature	235 °C to 246 °C
Cool-down slope	-3–0 °C/s
Reflow Cycle	
Max reflow cycle	1

NOTE

1. The above profile parameter requirements are for the measured temperature of the solder joints. Both the hottest and coldest spots of solder joints on the PCB should meet the above requirements.
2. If a conformal coating is necessary for the module, do NOT use any coating material that may chemically react with the PCB or shielding cover, and prevent the coating material from flowing into the module.
3. Avoid using ultrasonic technology for module cleaning since it can damage crystals inside the module.
4. Due to the complexity of the SMT process, please contact Quectel Technical Supports in advance for any situation that you are not sure about, or any process (e.g., selective soldering, ultrasonic soldering) that is not mentioned in **document [8]**.

8.3. Packaging Specifications

This chapter describes only the key parameters and process of packaging. All figures below are for reference only. The appearance and structure of the packaging materials are subject to the actual delivery.

The module adopts carrier tape packaging and details are as follow:

8.3.1. Carrier Tape

Dimension details are as follow:

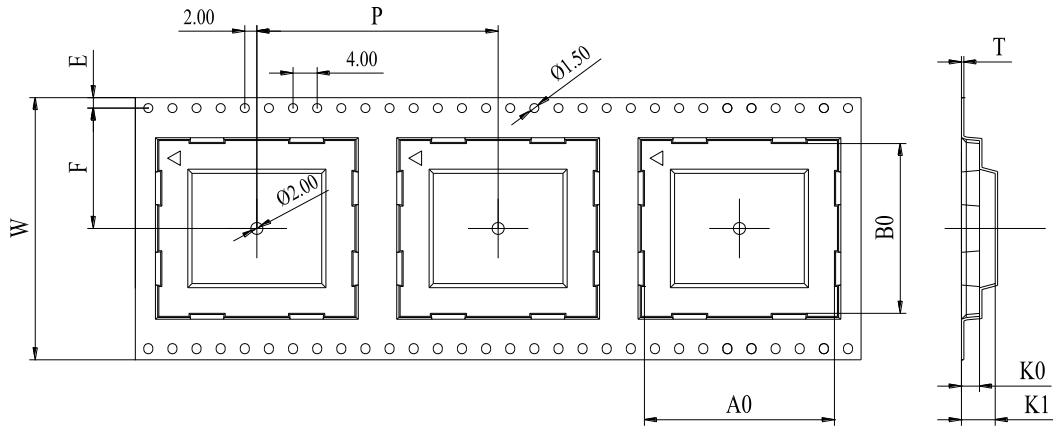

Figure 49: Carrier Tape Dimension Drawing

Table 80: Carrier Tape Dimension Table (Unit: mm)

W	P	T	A0	B0	K0	K1	F	E
44	32	0.35	20.2	24	3.15	6.65	20.2	1.75

8.3.2. Plastic Reel

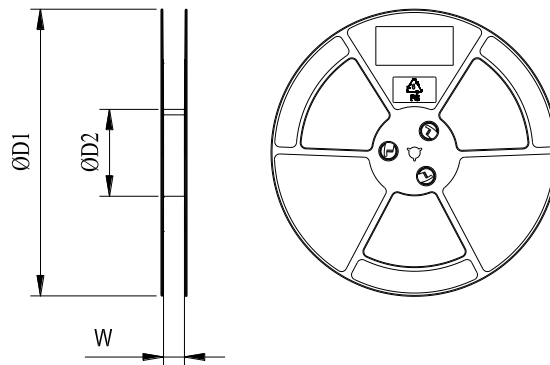

Figure 50: Plastic Reel Dimension Drawing

Table 81: Plastic Reel Dimension Table (Unit: mm)

$\varnothing D1$	$\varnothing D2$	W
330	100	44.5

8.3.3. Mounting Direction

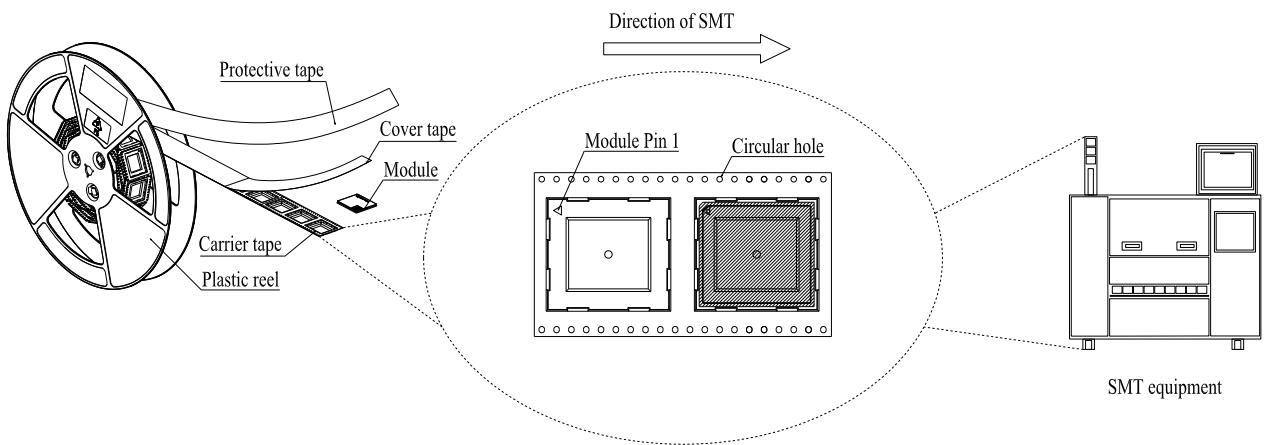
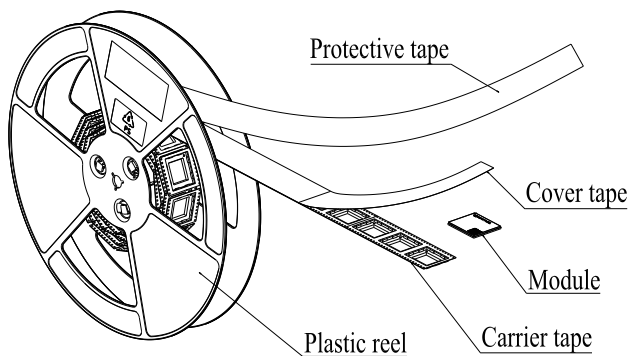

Figure 51: Mounting Direction

8.3.4. Packaging Process



Place the module into the carrier tape and use the cover tape to cover them; then wind the heat-sealed carrier tape to the plastic reel and use the protective tape for protection. One plastic reel can load 250 modules.

Place the packaged plastic reel, humidity indicator card and desiccant bag into a vacuum bag, then vacuumize it.

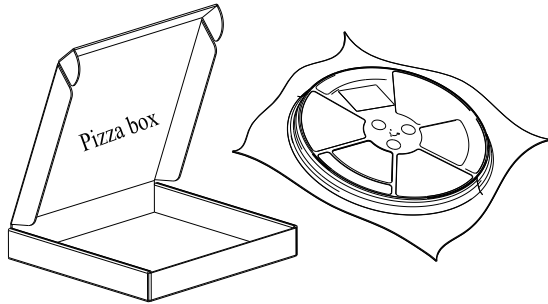
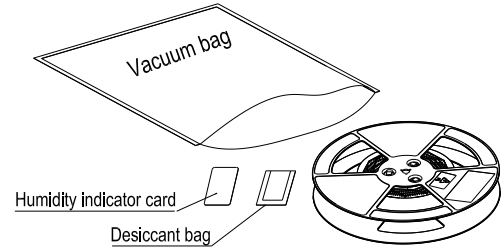

Place the vacuum-packed plastic reel into a pizza box.

Put 4 pizza boxes into 1 carton and seal it. One carton can pack 1000 modules.

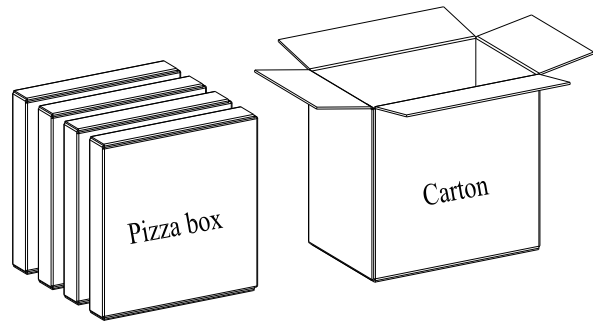

Figure 52: Packaging Process

Table 82: Packaging Specifications of the Module

MOQ for MP	Minimum Package: 250	Minimum Package × 4 = 1000
250	Size: 370 mm × 350 mm × 56 mm Net Weight: 0.61 kg Gross Weight: 1.35 kg	Size: 380 mm × 250 mm × 365 mm Net Weight: 2.45 kg Gross Weight: 6.28 kg

9 Appendix A References

Table 83: Related Documents

Document Name
[1] Quectel_BG95&BG77&BG600L_Series_GNSS_Application_Note
[2] Quectel_LTE_OPEN_EVB_User_Guide
[3] Quectel_BG95&BG77&BG600L_Series_AT_Commands_Manual
[4] Quectel_BG95&BG77&BG600L_Series_QuecOpen_Extended_QAPI_Reference_Manual
[5] Quectel_BG95&BG77&BG600L_Series_QuecOpen_Basic_QAPI_Reference_Manual
[6] Quectel_BG95&BG77&BG600L_Series_QCFG_AT_Commands_Manual
[7] Quectel_RF_Layout_Application_Note
[8] Quectel_Module_SMT_Application_Note

Table 84: Terms and Abbreviations

Abbreviation	Description
ADC	Analog-to-Digital Converter
API	Application Programming Interface
ASM	Antenna Switch Modules
BDS	BeiDou Navigation Satellite System
bps	Bits Per Second
CHAP	Challenge Handshake Authentication Protocol
CS	Coding Scheme

DFOTA	Delta Firmware Upgrade Over-The-Air
DL	Downlink
DRX	Discontinuous Reception
e-I-DRX	Extended Idle Mode Discontinuous Reception
eSIM	embedded Subscriber Identification Module
EDGE	Enhanced Data Rates for GSM Evolution
EGPRS	Enhanced General Packet Radio Service
EGSM	Extended GSM (Global System for Mobile Communications)
EPC	Evolved Packet Core
ESD	Electrostatic Discharge
ETSI	European Telecommunications Standards Institute
FDD	Frequency Division Duplex
GLONASS	Global Navigation Satellite System (Russia)
GMSK	Gaussian Minimum Shift Keying
GPS	Global Positioning System
GSM	Global System for Mobile Communications
HSS	Home Subscriber Server
I2C	Inter-Integrated Circuit
LDO	Low-dropout Regulator
LED	Light Emitting Diode
LGA	Land Grid Array
LNA	Low Noise Amplifier
LPF	Low-Pass Filter
LTE	Long Term Evolution
MCS	Modulation and Coding Scheme

MLCC	Multi-layer Ceramic Capacitor
MO	Mobile Originated
MOQ	Minimum Order Quantity
MSL	Moisture Sensitivity Level
MT	Mobile Terminated
M2M	Machine to Machine
PA	Power Amplifier
PAP	Password Authentication Protocol
PCB	Printed Circuit Board
PDN	Packet Data Network
PDU	Protocol Data Unit
PMIC	Power Management IC
POS	Point of Sale
PPP	Point-to-Point Protocol
PSM	Power Saving Mode
QZSS	Quasi-Zenith Satellite System
RAU	Route Area Update
RF	Radio Frequency
RHCP	Right Hand Circularly Polarized
Rx	Receive
SAW	Surface Acoustic Wave
SMD	Surface Mount Device
SMS	Short Message Service
SPI	Serial Peripheral Interface
TAU	Tracking Area Update

TCP	Transmission Control Protocol
TDM	Time-Division Multiplexing
TVS	Transient Voltage Suppressor
Tx	Transmit
UDP	User Datagram Protocol
UL	Uplink
UE	User Equipment
URC	Unsolicited Result Code
USB	Universal Serial Bus
(U)SIM	(Universal) Subscriber Identity Module
V _{max}	Maximum Voltage
V _{nom}	Nominal Voltage
V _{min}	Minimum Voltage
V _{IHmax}	Maximum High-level Input Voltage
V _{IHmin}	Minimum High-level Input Voltage
V _{ILmax}	Maximum Low-level Input Voltage
V _{ILmin}	Minimum Low-level Input Voltage
V _{OHmin}	Minimum High-level Output Voltage
V _{OLmax}	Maximum Low-level Output Voltage
VSWR	Voltage Standing Wave Ratio
WWAN	Wireless Wide Area Network
Wi-Fi	Wireless Fidelity
XO	Crystal Oscillator

10 Appendix B Compulsory Certifications

By the issue date of the document, BG95-M1, BG95-M2, BG95-M3, BG95-M5 and BG95-M6 have been certified by JATE and TELEC.

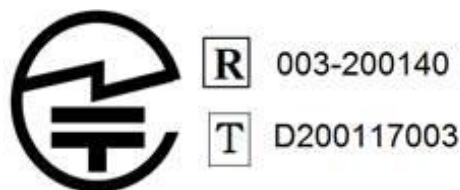

Figure 53: JATE/TELEC Certification ID of BG95-M1/M2

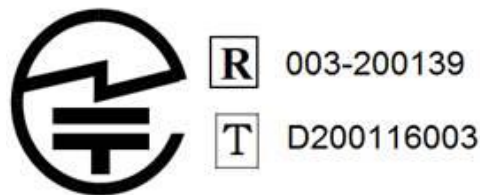

Figure 54: JATE/TELEC Certification ID of BG95-M3

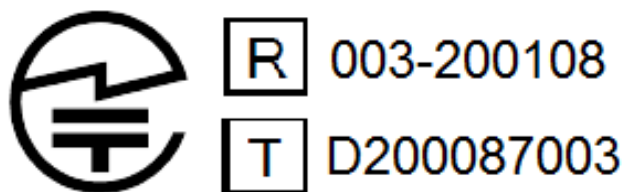

Figure 55: JATE/TELEC Certification ID of BG95-M5

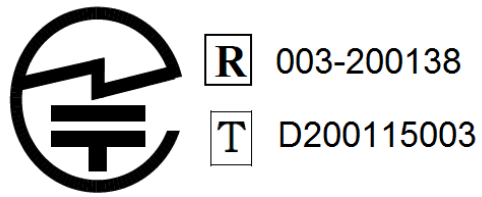

Figure 56: JATE/TELEC Certification ID of BG95-M6